

# Flexible Couplings RUPEX Series

# 8



8/2	<a href="#">Overview</a>
8/2	<a href="#">Benefits</a>
8/2	<a href="#">Application</a>
8/2	<a href="#">Design</a>
8/4	<a href="#">Function</a>
8/4	<a href="#">Technical data</a>
8/6	<b>Type RWN</b> <b>hub material grey cast iron</b>
8/6	<a href="#">Selection and ordering data</a>
8/8	<b>Type RWS</b> <b>hub material steel</b>
8/8	<a href="#">Selection and ordering data</a>
8/10	<b>Type RFN</b> <b>with hub in grey cast iron</b>
8/10	<a href="#">Selection and ordering data</a>
8/11	<b>Type RFS</b> <b>in steel</b>
8/11	<a href="#">Selection and ordering data</a>
8/12	<b>Type RWB</b> <b>with brake disk to DIN 15432</b>
8/12	<a href="#">Selection and ordering data</a>
8/14	<b>Type RBS</b> <b>with brake disk to DIN 15432</b> <b>Sizes 144 to 360</b>
8/14	<a href="#">Selection and ordering data</a>
8/16	<b>Type RBS</b> <b>with brake disk to DIN 15432</b> <b>Sizes 400 to 1000</b>
8/16	<a href="#">Selection and ordering data</a>
8/18	<b>Type RWB</b> <b>with brake drum to DIN 15431</b>
8/18	<a href="#">Selection and ordering data</a>
8/19	<b>Type RBS</b> <b>with brake drum to DIN 15431</b>
8/19	<a href="#">Selection and ordering data</a>
8/20	<b>Spare and wear parts</b>
8/20	<a href="#">Selection and ordering data</a>
Siemens MD 10.1 · 2011	

# FLENDER Standard Couplings

## Flexible Couplings – RUPEX Series

### General information

#### Overview

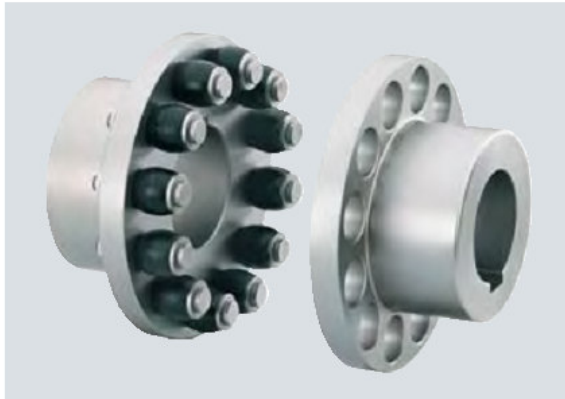

**Coupling suitable for potentially explosive environments. Complies with Directive 94/9/EC for:**

**CE Ex** II 2 G T4 / T5 / T6 D120 °C  
-30 °C ≤ T<sub>a</sub> ≤ +80 °C / +50 °C / +40 °C

**CE Ex** I M2

RUPEX pin and bush couplings link machine shafts and compensate for shaft misalignment with weak restorative forces. The torque is conducted through elastomer buffers, so the coupling has typically flexible rubber properties. Thanks to their robust design, RUPEX couplings are also suitable for rough operating conditions.

#### Benefits

RUPEX couplings can also hold loads when overloaded and are therefore especially suitable for drives for special safety and reliability requirements.

Torque shock loads and changing loads are no problem for robust, compact flexible RUPEX couplings.

The steel variant is also especially suitable for high-speed drives.

RUPEX couplings are fitted by putting together the coupling halves. Fitting with low torsional backlash is simplified by the barrel-shaped geometry of the buffers.

RUPEX couplings require little maintenance. Only the elastomer buffers, as wear parts, need be replaced and the coupled machines need not be moved to do so.

RUPEX couplings are suitable for reversing operation and horizontal and vertical fitting or fitting at any required angle.

8

#### Application

RUPEX couplings are available as a catalog standard in 26 sizes with a rated torque of between 200 Nm and 1300000 Nm.

The coupling is suitable for use at ambient temperatures of between -30 °C and +80 °C. By using alternative elastomer buffers, the permissible ambient temperature range can be extended to between -50 °C and +100 °C.

Frequently, the coupling is used to connect the gear shaft to the driven machine. In the case of drives without gear units, the cou-

pling is particularly suitable for operation in rough conditions or heavy-duty drives with electric motor drive. Ventilator drives with high ventilator mass and drives in the cement industry are typical applications.

Examples of particularly safety-relevant areas of application are cable railway drives, lifting gear for crane drives or escalator drives.

#### Design

A RUPEX coupling comprises two hub sections which are mounted on the machine shafts. The hub parts are connected positively by steel pins and elastomer buffers. The coupling can be fitted with add-on parts such as brake disks or brake drums. Up to size 360, the pins and buffers are fitted on one side. From size 400 up, the pins and buffers are fitted in the hubs on alternate sides.

##### Materials

##### Hubs

- Types RWN and RWB made of grey cast iron EN-GJL-250
- Types RWS and RBS made of steel with yield point higher than 400 N/mm<sup>2</sup>

##### Flange

- Types RFN, RFS made of steel

##### Pin

Material steel 42CrMo4, surface fine-machined

##### Buffer material

Material/description	Hardness	Identification	Ambient temperature
<b>NBR standard type</b>	<b>80 ShoreA</b>	<b>Buffer black</b>	<b>-30 °C ... +80 °C</b>
NBR electrically insulating	80 ShoreA	Buffer green	-30 °C ... +80 °C
NBR soft	65 ShoreA	Buffer black with green dot	-30 °C ... +80 °C
NBR hard	90 ShoreA	Buffer black with magenta dot	-30 °C ... +80 °C
NR for low temperature	80 ShoreA	Buffer black with white dot	-50 °C ... +50 °C
HNBR high temperature	80 ShoreA	Buffer black with red dot	-10 °C ... +100 °C

##### Brake disks

- Type RWB made of EN-GJS-400 spheroidal graphite cast iron
- Type RBS made of steel

##### Brake drums

- Type RWB made of EN-GJL-250 grey cast iron
- Type RBS made of steel

# FLENDER Standard Couplings

## Flexible Couplings – RUPEX Series

### General information

#### RUPEX pin and bush coupling types

Type	Description
RWN	Coupling made of grey cast iron
RWS	Coupling made of steel
RWB	Coupling made of grey cast iron with brake drum or brake disk
RBS	Coupling made of steel with brake drum or brake disk
RFN	Coupling made of grey cast iron in flange-shaft variant
RFS	Coupling made of steel in flange-shaft variant

Further application-related coupling types are available. Dimension sheets for and information on these are available on request.

#### RUPEX pin and bush coupling types on request

Type	Description
All	Coupling with axial backlash limitation
All	Coupling with pretensioned buffers
All	Coupling with lengthened pins and spacer sleeves
RKS	Coupling for engaging/disengaging during standstill
RWNH, RWSH	Coupling with extension piece
RBM	Coupling with lengthened pins for sliding rotor motors
RAK	Coupling combination RUPEX with ARPEX all-steel membrane coupling

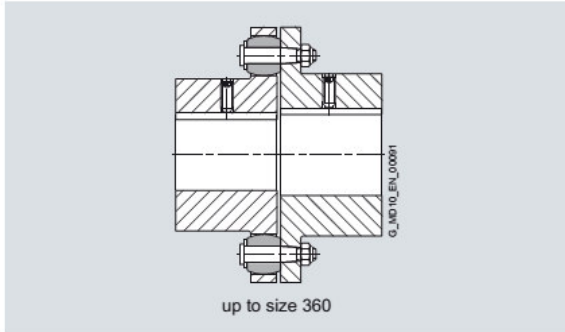

up to size 360

Types RWN/RWS – One-sided arrangement of pins and buffers

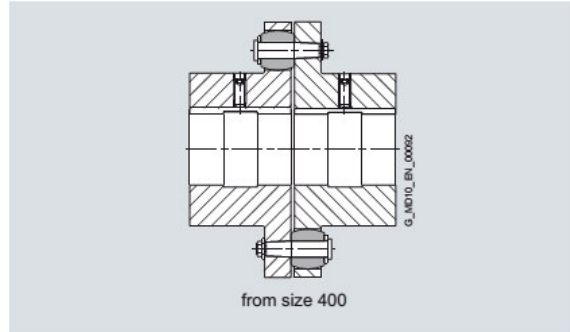

from size 400

Types RWN/RWS – Alternate-sided arrangement of pins and buffers

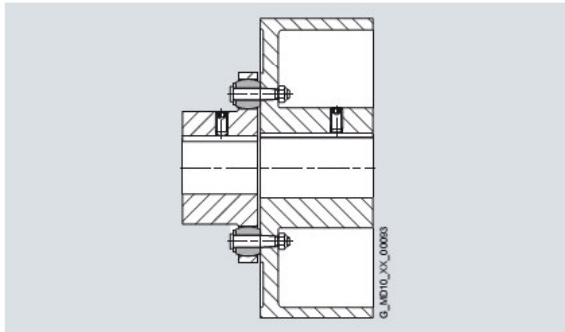

Types RWB/RBS with brake drum

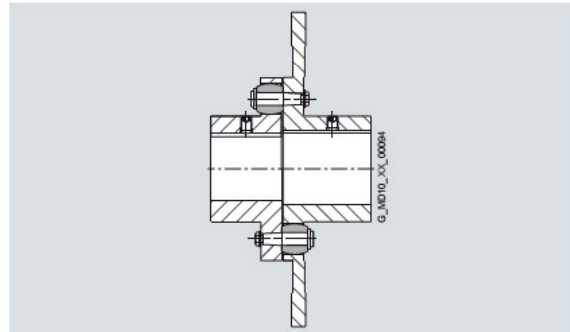

Types RWB/RBS with brake disk

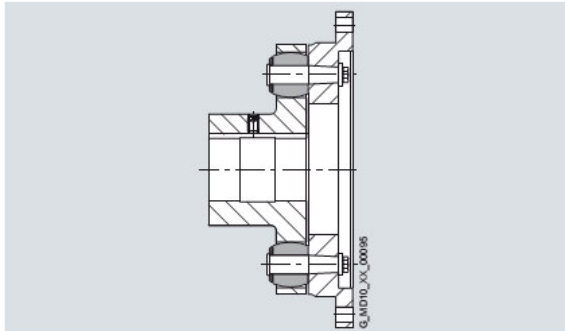

Types RFN, RFS

# FLENDER Standard Couplings

## Flexible Couplings – RUPEX Series

### General information

#### Function

The motor torque is transmitted to the hub on the drive side via the shaft-hub connection, which is mostly designed as a keyway connection. With the aid of elastomer buffers mounted on steel pins, the torque is conducted to the hub on the output side.

The hub on the output side further transmits the torque to the driven machine or a gear unit located in between. Because of the primarily compression-loaded buffers, the coupling has a progressive torsional stiffness.

#### Technical data

##### Power ratings

Size	Rated torque for buffer type			Torsional stiffness at 50 % capacity utilization for buffer type			Assembly Gap dimension $\Delta S$ mm	Permitted shaft misalignment at speed $n = 1500 \text{ rpm}^{1)}$		
	65 ShoreA	<b>80 ShoreA</b>	90 ShoreA	65 ShoreA	<b>80 ShoreA</b>	90 ShoreA		Axial $\Delta K_a$ mm	Radial $\Delta K_r$ mm	Angle $\Delta K_w$ Degree
	$\bar{T}_{KN}$ Nm	$\bar{T}_{KN}$ Nm	$\bar{T}_{KN}$ Nm	$C_{Tdyn} 50 \%$ kNm/rad	$C_{Tdyn} 50 \%$ kNm/rad	$C_{Tdyn} 50 \%$ kNm/rad				
<b>105</b>	120	<b>200</b>	200	5	<b>13</b>	21	1.0	0.2	0.2	0.11
<b>125</b>	210	<b>350</b>	350	9	<b>25</b>	37	1.0	0.2	0.2	0.10
<b>144</b>	300	<b>500</b>	500	15	<b>43</b>	64	1.0	0.23	0.23	0.09
<b>162</b>	450	<b>750</b>	750	20	<b>55</b>	83	1.5	0.25	0.25	0.09
<b>178</b>	570	<b>950</b>	950	31	<b>85</b>	130	1.5	0.27	0.27	0.09
<b>198</b>	780	<b>1300</b>	1300	43	<b>123</b>	187	1.5	0.29	0.29	0.08
<b>228</b>	1300	<b>2200</b>	2200	65	<b>184</b>	270	1.5	0.3	0.3	0.08
<b>252</b>	1650	<b>2750</b>	2750	92	<b>256</b>	380	1.5	0.34	0.34	0.08
<b>285</b>	2600	<b>4300</b>	4300	141	<b>390</b>	560	1.5	0.36	0.36	0.07
<b>320</b>	3300	<b>5500</b>	5500	195	<b>540</b>	790	1.5	0.4	0.4	0.07
<b>360</b>	4700	<b>7800</b>	7800	276	<b>610</b>	940	1.5	0.43	0.43	0.07
<b>400</b>	7500	<b>12500</b>	12500	410	<b>1130</b>	1710	1.5	0.48	0.48	0.07
<b>450</b>	11000	<b>18500</b>	18500	570	<b>1600</b>	2380	1.5	0.52	0.52	0.07
<b>500</b>	15000	<b>25000</b>	25000	860	<b>2350</b>	3600	1.5	0.57	0.57	0.07
<b>560</b>	23500	<b>39000</b>	39000	1130	<b>3070</b>	4700	2.0	0.62	0.62	0.06
<b>630</b>	31000	<b>52000</b>	52000	1640	<b>4600</b>	7400	2.0	0.68	0.68	0.06
<b>710</b>	50000	<b>84000</b>	84000	2560	<b>7200</b>	10900	2.0	0.75	0.75	0.06
<b>800</b>	66000	<b>110000</b>	110000	3900	<b>10700</b>	16700	2.0	0.84	0.84	0.06
<b>900</b>	90000	<b>150000</b>	150000	5200	<b>14300</b>	22500	2.5	0.93	0.93	0.06
<b>1000</b>	115000	<b>195000</b>	195000	7700	<b>21300</b>	33000	2.5	1.03	1.03	0.06
<b>1120</b>	160000	<b>270000</b>	270000	9800	<b>27300</b>	44000	2.5	1.14	1.14	0.06
<b>1250</b>	205000	<b>345000</b>	345000	14000	<b>39000</b>	62000	2.5	1.26	1.26	0.06
<b>1400</b>	320000	<b>530000</b>	530000	22800	<b>62000</b>	97000	3.0	1.39	1.39	0.06
<b>1600</b>	450000	<b>750000</b>	750000	37000	<b>103000</b>	160000	3.0	1.55	1.55	0.06
<b>1800</b>	585000	<b>975000</b>	975000	48000	<b>133000</b>	208000	4.0	1.76	1.76	0.06
<b>2000</b>	780000	<b>1300000</b>	1300000	73000	<b>201000</b>	314000	4.0	2.17	2.17	0.06

All product codes listed below apply to standard buffers of NBR material in the 80 ShoreA variant.

<sup>1)</sup> The maximum speed of the respective type must be noted. For further information on permissible shaft misalignment, please see the operating instructions.

# FLENDER Standard Couplings

## Flexible Couplings – RUPEX Series

### General information

For maximum coupling torque:

$$T_{Kmax} = 3.0 \cdot T_{KN}$$

For overload torque:

$$T_{KOL} = 4 \cdot T_{KN}$$

For coupling fatigue torque:

$$T_{KW} = 0.20 \cdot T_{KN}$$

The axial misalignment may occur dynamically at frequencies up to 10 Hz.

For fitting, a maximum gap dimension of S max. = S + ΔS and a minimum gap dimension of S min. = S – ΔS are permitted.

#### Torsional stiffness and damping

The values stated in the above table apply to a capacity utilization of 50 %, an excitation amplitude of 10 %  $T_{KN}$  with the frequency 10 Hz and an ambient temperature of 20 °C. Dynamic torsional stiffness is dependent on load and increases in proportion to capacity utilization. The following table shows the correction factors for different nominal loads.

$$C_{Tdyn} = C_{Tdyn\ 50\ \%} \cdot FK_C$$

Correction factor FK <sub>C</sub> 65/80/90 ShoreA	Capacity utilization $T_N / T_{KN}$							
	20 %	40 %	50 %	60 %	70 %	80 %	90 %	100 %
	0.51	0.83	1.00	1.18	1.38	1.58	1.80	2.03

#### The damping coefficient is $\Psi = 1.4$

Furthermore, torsional stiffness and damping depend on the ambient temperature and the frequency and amplitude of the torsional vibration excitation. More precise torsional stiffness and damping parameters on request.

#### Permitted shaft misalignment

The permitted shaft misalignment depends on the operating speed. As the speed increases, lower shaft misalignment values are permitted. The following table shows the correction factors for different speeds.

The maximum speed for the respective coupling size and type must be observed!

$$\Delta K_{perm} = \Delta K_{1500} \cdot FK_V$$

Correction factor FK <sub>V</sub>	Speed in rpm			
	500	1000	1500	3000
	1.60	1.20	1.0	0.70

The axial misalignment may occur dynamically at frequencies up to 10 Hz. For fitting, a maximum gap dimension of S max. = S + ΔS and a minimum gap dimension of S min. = S – ΔS are permitted. Shaft misalignments  $\Delta K_a$ ,  $\Delta K_r$  and  $\Delta K_w$  may occur simultaneously.

# FLENDER Standard Couplings Flexible Couplings – RUPEX Series

Type RWN - hub material grey cast iron

## Selection and ordering data

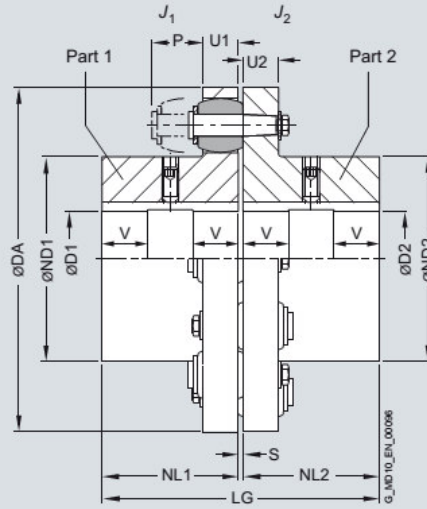

Size	Rated torque buffer 80 ShoreA $T_{KN}$ Nm	Speed $n_{Kmax}$ rpm	Dimensions in mm													Mass moment of inertia		Product code Order codes for bore diameters and tolerances are specified in catalog section 3	Weight $m$ kg	
			Bore with keyway to DIN 6885		DA	ND1	ND2	NL1/ S	U1	U2	P	LG	$J_1$	$J_2$						
			D1 min.	D2 max.																
105 <sup>1)</sup>	200	7000	-	32	-	38	105	53	59	45	3	13	12	30	93	0.001	0.001	2LC0130-1AA ■ ■ -0AA0	1.9	
125 <sup>1)</sup>	350	6000	-	40	-	48	125	65	68	50	3	16	15	35	103	0.003	0.003	2LC0130-2AA ■ ■ -0AA0	3.2	
144	500	5250	-	45	-	55	144	76	84	55	3	16	15	35	113	0.004	0.006	2LC0130-3AA ■ ■ -0AA0	4.5	
162	750	4650	-	50	-	60	162	85	92	60	3.5	20	18	40	123.5	0.007	0.013	2LC0130-4AA ■ ■ -0AA0	6.7	
178	950	4200	-	60	-	70	178	102	108	70	3.5	20	18	40	143.5	0.014	0.022	2LC0130-5AA ■ ■ -0AA0	9.7	
198	1300	3750	-	70	-	80	198	120	128	80	3.5	20	18	40	163.5	0.022	0.030	2LC0130-6AA ■ ■ -0AA0	12.9	
228	2200	3300	-	80	-	90	228	129	140	90	3.5	26	24	50	183.5	0.038	0.071	2LC0130-7AA ■ ■ -0AA0	19	
252	2750	3000	-	90	-	100	252	150	160	100	3.5	26	24	50	203.5	0.07	0.12	2LC0130-8AA ■ ■ -0AA0	26.3	
285	4300	2650	48	100	48	110	285	164	175	110	4.5	32	30	60	224.5	0.13	0.22	2LC0131-0AA ■ ■ -0AA0	39	
320	5500	2350	55	110	55	120	320	180	192	125	4.5	32	30	60	254.5	0.23	0.30	2LC0131-1AA ■ ■ -0AA0	53	
360	7800	2100	65	120	65	130	360	200	210	140	4.5	42	42	75	284.5	0.41	0.70	2LC0131-2AA ■ ■ -0AA0	78	
400	12500	2050	75	140	75	140	400	230	230	160	4.5	42	42	75	324.5	0.87	0.87	2LC0131-3AA ■ ■ -0AA0	105	
450	18500	1800	85	160	85	160	450	260	260	180	5.5	52	52	90	365.5	1.7	1.7	2LC0131-4AA ■ ■ -0AA0	156	
500	25000	1600	95	180	95	180	500	290	290	200	5.5	52	52	90	405.5	2.8	2.8	2LC0131-5AA ■ ■ -0AA0	200	
560	39000	1450	100	140	100	140	560	250	250	220	6	68	68	120	446	4.6	4.6	2LC0131-6AA ■ ■ -0AA0	280	
			140	180	140	180			300	300							5	5	2LC0131-6AA ■ ■ -0AA0	290
			180	200	180	200			320	320							5.1	5.1	2LC0131-6AA ■ ■ -0AA0	295
630	52000	1280	100	140	100	140	630	250	250	240	6	68	68	120	486	7.2	7.2	2LC0131-7AA ■ ■ -0AA0	345	
			140	180	140	180			300	300							7.7	7.7	2LC0131-7AA ■ ■ -0AA0	370
			180	220	180	220			355	355							8.4	8.4	2LC0131-7AA ■ ■ -0AA0	400
710	84000	1150	110	160	110	160	710	290	290	260	7	80	80	140	527	13	13	2LC0131-8AA ■ ■ -0AA0	510	
			160	200	160	200			330	330							14	14	2LC0131-8AA ■ ■ -0AA0	515
			200	240	200	240			385	385							15	15	2LC0131-8AA ■ ■ -0AA0	540

- ØD1:
  - Without finished bore up to size 500, from size 560 for 1st diameter range D1 – Without order codes
  - Without finished bore from size 560 for 2nd diameter range D1 – Without order codes
  - Without finished bore from size 710 for 3rd diameter range D1 – Without order codes
  - With finished bore – With order codes for diameter and tolerance (product code without -Z)
- ØD2:
  - Without finished bore up to size 500, from size 560 for 1st diameter range D1 – Without order codes
  - Without finished bore from size 560 for 2nd diameter range D2 – Without order codes
  - Without finished bore from size 710 for 3rd diameter range D2 – Without order codes
  - With finished bore – With order codes for diameter and tolerance (product code without -Z)

<sup>1)</sup> Hub material EN-GJS 400 spheroidal graphite cast iron.

# FLENDER Standard Couplings Flexible Couplings – RUPEX Series

Type RWN - hub material grey cast iron

Size	Rated torque buffer 80 ShoreA $T_{KN}$	Speed $n_{kmax}$	Dimensions in mm													Mass moment of inertia		Product code Order codes for bore diameters and tolerances are specified in catalog section 3	Weight $m$		
			Bore with keyway to DIN 6885				DA	ND1	ND2	NL1/ S NL2	U1	U2	P	LG	$J_1$	$J_2$					
			D1	D2	min.	max.															
800	110000	1000	125	180	125	180	800	320	320	290	7	80	80	140	587	22	22	2LC0132-0AA ■ ■ -0AA0	670		
			180	220	180	220			360	360							23		23	2LC0132-0AA ■ ■ -0AA0	690
			220	260	220	260			420	420							24.5		24.5	2LC0132-0AA ■ ■ -0AA0	730
900	150000	900	140	220	140	220	900	360	360	320	7.5	90	90	160	647.5	39	39	2LC0132-1AA ■ ■ -0AA0	940		
			220	260	220	260			425	425							41		41	2LC0132-1AA ■ ■ -0AA0	960
			260	290	260	290			465	465							43		43	2LC0132-1AA ■ ■ -0AA0	1030
1000	195000	810	150	240	150	240	1000	395	395	350	7.5	90	90	160	707.5	60	60	2LC0132-2AA ■ ■ -0AA0	1200		
			240	280	240	280			460	460							63		63	2LC0132-2AA ■ ■ -0AA0	1250
			280	320	280	320			515	515							68		68	2LC0132-2AA ■ ■ -0AA0	1310
1120	270000	700	160	200	160	200	1120	360	360	380	8.5	100	100	180	768.5	98	98	2LC0132-3AA ■ ■ -0AA0	1470		
			200	250	200	250			410	410							100		100	2LC0132-3AA ■ ■ -0AA0	1510
			250	300	250	300			495	495							105		105	2LC0132-3AA ■ ■ -0AA0	1600
			300	350	300	350			560	560							110		110	2LC0132-3AA ■ ■ -0AA0	1690
1250	345000	650	180	230	180	230	1250	410	410	420	8.5	100	100	180	848.5	150	150	2LC0132-4AA ■ ■ -0AA0	1850		
			230	280	230	280			460	460							155		155	2LC0132-4AA ■ ■ -0AA0	1900
			280	330	280	330			540	540							165		165	2LC0132-4AA ■ ■ -0AA0	2025
			330	380	330	380			610	610							175		175	2LC0132-4AA ■ ■ -0AA0	2210
1400	530000	570	200	260	200	260	1400	465	465	480	9	120	120	210	969	290	290	2LC0132-5AA ■ ■ -0AA0	2820		
			260	320	260	320			525	525							300		300	2LC0132-5AA ■ ■ -0AA0	2900
			320	380	320	380			620	620							310		310	2LC0132-5AA ■ ■ -0AA0	3180
			380	440	380	440			700	700							330		330	2LC0132-5AA ■ ■ -0AA0	3260
1600	750000	500	260	320	260	320	1600	565	565	540	9	120	120	210	1089	490	490	2LC0132-6AA ■ ■ -0AA0	3780		
			320	380	320	380			625	625							500		500	2LC0132-6AA ■ ■ -0AA0	3870
			380	440	380	440			720	720							530		530	2LC0132-6AA ■ ■ -0AA0	4150
			440	480	440	480			770	770							550		550	2LC0132-6AA ■ ■ -0AA0	4290
1800	975000	450	320	380	320	380	1800	660	660	600	12	140	140	240	1212	850	850	2LC0132-7AA ■ ■ -0AA0	5550		
			380	440	380	440			720	720							930		930	2LC0132-7AA ■ ■ -0AA0	5630
			440	500	440	500			820	820							980		980	2LC0132-7AA ■ ■ -0AA0	6000
			500	540	500	540			870	870							1050		1050	2LC0132-7AA ■ ■ -0AA0	6250
2000	1300000	400	380	440	380	440	2000	760	760	660	12	140	140	240	1332	1350	1350	2LC0132-8AA ■ ■ -0AA0	6800		
			440	500	440	500			820	820							1400		1400	2LC0132-8AA ■ ■ -0AA0	7000
			500	560	500	560			920	920							1500		1500	2LC0132-8AA ■ ■ -0AA0	7350
			560	600	560	600			960	960							1550		1550	2LC0132-8AA ■ ■ -0AA0	7620

- ∅D1:
- Without finished bore up to size 500, from size 560 for 1st diameter range D1 – Without order codes
  - Without finished bore from size 560 for 2nd diameter range D1 – Without order codes
  - Without finished bore from size 560 for 3rd diameter range D1 – Without order codes
  - Without finished bore from size 1120 for 4th diameter range D1 – Without order codes
  - With finished bore – With order codes for diameter and tolerance (product code without **-Z**)
- ∅D2:
- Without finished bore up to size 500, from size 560 for 1st diameter range D2 – Without order codes
  - Without finished bore from size 560 for 2nd diameter range D2 – Without order codes
  - Without finished bore from size 560 for 3rd diameter range D2 – Without order codes
  - Without finished bore from size 1120 for 4th diameter range D2 – Without order codes
  - With finished bore – With order codes for diameter and tolerance (product code without **-Z**)

From size 560 bores D1 and D2 are each provided with a recess of  $D = +1$  mm halfway along the hub.  $V \approx 1/3$  NL

The hub diameter of the component part is assigned according to the diameter of the finished bore. Where bore diameters overlap, the component with the smaller hub diameter is always selected.

Weight and mass moments of inertia apply to maximum bore diameters.

Ordering example:  
RUPEX RWN coupling, size 710,  
Part 1: hub left with bore 180H7 mm, with keyway to DIN 6885 and set screw,  
Part 2: hub right with bore 200H7 mm, with keyway to DIN 6885 and set screw.

Product code:  
**2LC0131-8AA99-0AA0**  
**L2B+M2D**

The product code applies to standard buffers of 80 ShoreA; the product code for alternative buffer types is available on request.

# FLENDER Standard Couplings Flexible Couplings – RUPEX Series

Type RWS - hub material steel

## Selection and ordering data

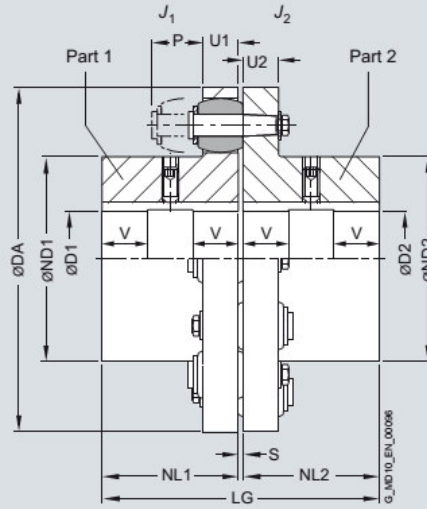

8

Size	Rated torque buffer 80 ShoreA $T_{KN}$ Nm	Speed $n_{Kmax}$ rpm	Dimensions in mm Bore with keyway to DIN 6885													Mass moment of inertia		Product code Order codes for bore diameters and tolerances are specified in catalog section 3	Weight $m$ kg
			D1 min.	D2 max.	DA	ND1	ND2	NL1/ S NL2	U1	U2	P	LG	$J_1$	$J_2$					
105	200	10000	-	32	-	38	105	53	59	45	3	13	12	30	93	0.001	0.001	2LC0130-1AB ■ ■ -0AA0	1.9
125	350	9000	-	42	-	48	125	65	68	50	3	16	15	35	103	0.003	0.003	2LC0130-2AB ■ ■ -0AA0	3.2
144	500	7800	-	50	-	60	144	76	84	55	3	16	15	35	113	0.004	0.006	2LC0130-3AB ■ ■ -0AA0	4.5
162	750	6900	-	55	-	65	162	85	92	60	3.5	20	18	40	123.5	0.007	0.013	2LC0130-4AB ■ ■ -0AA0	6.7
178	950	6300	-	70	-	75	178	102	108	70	3.5	20	18	40	143.5	0.014	0.022	2LC0130-5AB ■ ■ -0AA0	9.7
198	1300	5600	-	80	-	85	198	120	128	80	3.5	20	18	40	163.5	0.022	0.030	2LC0130-6AB ■ ■ -0AA0	12.9
228	2200	4900	-	85	-	95	228	129	140	90	3.5	26	24	50	183.5	0.038	0.071	2LC0130-7AB ■ ■ -0AA0	19
252	2750	4400	-	100	-	110	252	150	160	100	3.5	26	24	50	203.5	0.07	0.12	2LC0130-8AB ■ ■ -0AA0	26.3
285	4300	3900	48	110	48	120	285	164	175	110	4.5	32	30	60	224.5	0.13	0.21	2LC0131-0AB ■ ■ -0AA0	39
320	5500	3500	55	125	55	130	320	180	192	125	4.5	32	30	60	254.5	0.23	0.32	2LC0131-1AB ■ ■ -0AA0	53
360	7800	3100	65	135	65	140	360	200	210	140	4.5	42	42	75	284.5	0.41	0.69	2LC0131-2AB ■ ■ -0AA0	78
400	12500	2800	75	150	75	150	400	230	230	160	4.5	42	42	75	324.5	0.92	0.92	2LC0131-3AB ■ ■ -0AA0	110
450	18500	2500	85	170	85	170	450	260	260	180	5.5	52	52	90	365.5	1.7	1.7	2LC0131-4AB ■ ■ -0AA0	163
500	25000	2200	95	190	95	190	500	290	290	200	5.5	52	52	90	405.5	2.8	2.8	2LC0131-5AB ■ ■ -0AA0	217
560	39000	2000	100	165	100	165	560	250	250	220	6	68	68	120	446	4.8	4.8	2LC0131-6AB ■ ■ -0AA0	274
			165	200	165	200	300	300	5.2	5.2	2LC0131-6AB ■ ■ -0AA0	292							
			200	210	200	210	320	320	5.4	5.4	2LC0131-6AB ■ ■ -0AA0	305							
630	52000	1800	100	165	100	165	630	250	250	240	6	68	68	120	486	7.6	7.6	2LC0131-7AB ■ ■ -0AA0	352
			165	200	165	200	300	300	7.9	7.9	2LC0131-7AB ■ ■ -0AA0	370							
			200	235	200	235	355	355	8.7	8.7	2LC0131-7AB ■ ■ -0AA0	400							
710	84000	1600	110	190	110	190	710	290	290	260	7	80	80	140	527	14.4	14.4	2LC0131-8AB ■ ■ -0AA0	507
			190	220	190	220	330	330	14.6	14.6	2LC0131-8AB ■ ■ -0AA0	530							
			220	250	220	250	385	385	15.9	15.9	2LC0131-8AB ■ ■ -0AA0	560							

- øD1:
- Without finished bore up to size 500, from size 560 for 1st diameter range D1 – Without order codes
  - Without finished bore from size 560 for 2nd diameter range D1 – Without order codes
  - Without finished bore from size 560 for 3rd diameter range D1 – Without order codes
  - With finished bore – With order codes for diameter and tolerance (product code without -Z)
- øD2:
- Without finished bore up to size 500, from size 560 for 1st diameter range D1 – Without order codes
  - Without finished bore from size 560 for 2nd diameter range D2 – Without order codes
  - Without finished bore from size 560 for 3rd diameter range D2 – Without order codes
  - With finished bore – With order codes for diameter and tolerance (product code without -Z)



# FLENDER Standard Couplings

## Flexible Couplings – RUPEX Series

Type RWS - hub material steel

Size	Rated torque buffer 80 ShoreA $T_{KN}$	Speed $n_{Kmax}$ rpm	Dimensions in mm Bore with keyway to DIN 6885												Mass moment of inertia		Product code Order codes for bore diameters and tolerances are specified in catalog section 3	Weight $m$ kg
			D1		D2		DA	ND1	ND2	NL1 NL2	S	U1 U2	P	LG	$J_1$	$J_2$		
			min.	max.	min.	max.												
800	110000	1400	125	210	125	210	800	320	320	290	7	80	140	587	23.1	23.1	2LC0132-0AB ■ ■ -0AA0	683
			210	240	210	240		360	360	23.3					23.3	2LC0132-0AB ■ ■ -0AA0		715
			240	280	240	280		420	420	25.7					25.7	2LC0132-0AB ■ ■ -0AA0		762
900	150000	1250	140	210	140	210	900	320	320	320	7.5	90	160	647.5	40	40	2LC0132-1AB ■ ■ -0AA0	907
			210	240	210	240		360	360	41					41	2LC0132-1AB ■ ■ -0AA0		933
			240	280	240	280		425	425	44					44	2LC0132-1AB ■ ■ -0AA0		1000
			280	310	280	310		465	465	45					45	2LC0132-1AB ■ ■ -0AA0		1025
1000	195000	1100	150	230	150	230	1000	355	355	350	7.5	90	160	707.5	63	63	2LC0132-2AB ■ ■ -0AA0	1170
			230	260	230	260		395	395	64					64	2LC0132-2AB ■ ■ -0AA0		1208
			260	300	260	300		460	460	68					68	2LC0132-2AB ■ ■ -0AA0		1290
			300	340	300	340		515	515	70					70	2LC0132-2AB ■ ■ -0AA0		1343
1120	270000	1000	160	240	160	240	1120	360	360	380	8.5	100	180	768.5	105	105	2LC0132-3AB ■ ■ -0AA0	1560
			240	270	240	270		410	410	106					106	2LC0132-3AB ■ ■ -0AA0		1660
			270	330	270	330		495	495	109					109	2LC0132-3AB ■ ■ -0AA0		1730
			330	370	330	370		560	560	119					119	2LC0132-3AB ■ ■ -0AA0		1870
1250	345000	900	180	270	180	270	1250	410	410	420	8.5	100	180	848.5	168	168	2LC0132-4AB ■ ■ -0AA0	2000
			270	300	270	300		460	460	172					172	2LC0132-4AB ■ ■ -0AA0		2150
			300	360	300	360		540	540	179					179	2LC0132-4AB ■ ■ -0AA0		2200
			360	400	360	400		610	610	189					189	2LC0132-4AB ■ ■ -0AA0		2420
1400	530000	800	200	310	200	310	1400	465	465	480	9	120	210	969	316	316	2LC0132-5AB ■ ■ -0AA0	3020
			310	350	310	350		525	525	322					322	2LC0132-5AB ■ ■ -0AA0		3120
			350	410	350	410		620	620	337					337	2LC0132-5AB ■ ■ -0AA0		3350
			410	460	410	460		700	700	357					357	2LC0132-5AB ■ ■ -0AA0		3570
1600	750000	700	260	370	260	370	1600	565	565	540	9	120	210	1089	540	540	2LC0132-6AB ■ ■ -0AA0	3890
			370	410	370	410		625	625	554					554	2LC0132-6AB ■ ■ -0AA0		4270
			410	480	410	480		720	720	587					587	2LC0132-6AB ■ ■ -0AA0		4300
			480	510	480	510		770	770	611					611	2LC0132-6AB ■ ■ -0AA0		4630
1800	975000	600	320	440	320	440	1800	660	660	600	12	140	240	1212	1043	1043	2LC0132-7AB ■ ■ -0AA0	6230
			440	480	440	480		720	720	1072					1072	2LC0132-7AB ■ ■ -0AA0		6460
			480	540	480	540		820	820	1122					1122	2LC0132-7AB ■ ■ -0AA0		6770
			540	580	540	580		870	870	1143					1143	2LC0132-7AB ■ ■ -0AA0		7030
2000	1300000	550	380	500	380	500	2000	760	760	660	12	140	240	1332	1628	1628	2LC0132-8AB ■ ■ -0AA0	8140
			500	540	500	540		820	820	1664					1664	2LC0132-8AB ■ ■ -0AA0		8430
			540	610	540	610		920	920	1735					1735	2LC0132-8AB ■ ■ -0AA0		8860
			610	640	610	640		960	960	1793					1793	2LC0132-8AB ■ ■ -0AA0		9050

- ∅D1:
  - Without finished bore up to size 500, from size 560 for 1st diameter range D1 – Without order codes
  - Without finished bore from size 560 for 2nd diameter range D1 – Without order codes
  - Without finished bore from size 560 for 3rd diameter range D1 – Without order codes
  - Without finished bore from size 900 for 4th diameter range D1 – Without order codes
  - With finished bore – With order codes for diameter and tolerance (product code without -Z)
- ∅D2:
  - Without finished bore up to size 500, from size 560 for 1st diameter range D1 – Without order codes
  - Without finished bore from size 560 for 2nd diameter range D2 – Without order codes
  - Without finished bore from size 560 for 3rd diameter range D2 – Without order codes
  - Without finished bore from size 900 for 4th diameter range D2 – Without order codes
  - With finished bore – With order codes for diameter and tolerance (product code without -Z)

From size 560 bores D1 and D2 are each provided with a recess of  $D = +1$  mm halfway along the hub.  $V \approx 1/3$  NL

The hub diameter of the component part is assigned according to the diameter of the finished bore. Where bore diameters overlap, the component with the smaller hub diameter is always selected.

Weight and mass moments of inertia apply to maximum bore diameters.

Ordering example:

RUPEX RWS coupling, size 710,  
Part 1: Hub left with bore 180H7 mm, with keyway to DIN 6885 and set screw,  
Part 2: Hub right with bore 200H7 mm, with keyway to DIN 6885 and set screw.

Coupling balanced G6.3 in accordance with the half parallel key standard.

Product code:  
**2LC0131-8AB99-0AA0-Z**  
**L2B+M2D+W02**

The product code applies to standard buffers of 80 ShoreA; the product code for alternative buffer types is available on request.

# FLENDER Standard Couplings Flexible Couplings – RUPEX Series

Type RFN with hub in grey cast iron

## Selection and ordering data

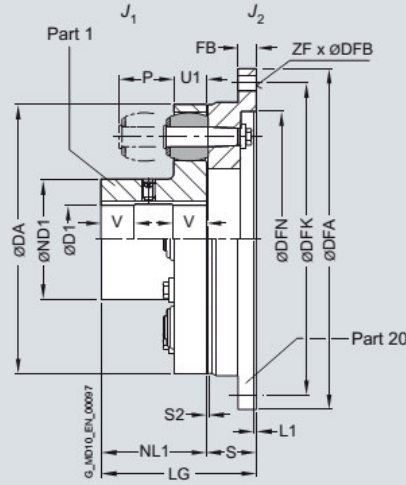

For dimensions U1, P and S2, see type RWN.

Size	Rated torque buffer 80 ShoreA $T_{KN}$ Nm	Speed $n_{Kmax}$ rpm	Dimensions in mm										Mass moment of inertia		Product code Order codes for bore diameters and tolerances are specified in catalog section 3	Weight $m$ kg						
			Bore with keyway to DIN 6885			Flange connection							$J_1$	$J_2$								
			D1 min. max.	DA	ND1	NL1	S	LG	DFA h8	FB	DFN H7	L1	DFK	ZF	DFB	kgm <sup>2</sup>	kgm <sup>2</sup>					
105	200	7000	- 32	105	53	45	26	71	158	10			142	6	9	0.001	0.005	2LC0130-1AJ	1-0AA0	2.3		
125	350	6000	- 42	125	65	50	31	81	180	13			160	6	11	0.003	0.012	2LC0130-2AJ	1-0AA0	4.2		
144	500	5250	- 45	144	76	55	31	86	200	13			180	7	11	0.004	0.018	2LC0130-3AJ	1-0AA0	5.0		
162	750	4650	- 50	162	85	60	37.5	97.5	220	13			200	8	11	0.007	0.032	2LC0130-4AJ	1-0AA0	7.3		
178	950	4200	- 60	178	102	70	37.5	107.5	248	16			224	8	14	0.014	0.055	2LC0130-5AJ	1-0AA0	10		
198	1300	3750	- 70	198	120	80	37.5	117.5	274	16			250	8	14	0.022	0.080	2LC0130-6AJ	1-0AA0	13		
228	2200	3300	- 80	228	129	90	45.5	135.5	314	20			282	8	18	0.038	0.18	2LC0130-7AJ	1-0AA0	20		
252	2750	3000	- 90	252	150	100	45.5	145.5	344	20			312	8	18	0.07	0.26	2LC0130-8AJ	1-0AA0	25		
285	4300	2650	48	100	285	164	110	55.5	165.5	380	22		348	9	18	0.13	0.46	2LC0131-0AJ	1-0AA0	38		
320	5500	2350	55	110	320	180	125	55.5	175.5	430	25		390	9	22	0.23	0.76	2LC0131-1AJ	1-0AA0	50		
360	7800	2100	65	120	360	200	140	70.5	210.5	480	25		440	10	22	0.41	1.4	2LC0131-2AJ	1-0AA0	76		
400	12500	2050	75	140	400	230	160	74.5	234.5	520	50	380	4	480	10	22	0.87	1.8	2LC0131-3AJ	1-0AA0	125	
450	18500	1800	85	160	450	260	180	85.5	265.5	575	45	428	6	528	12	26	1.7	3.2	2LC0131-4AJ	1-0AA0	170	
500	25000	1600	95	180	500	290	200	85.5	285.5	620	45	475	6	570	12	26	2.8	4.3	2LC0131-5AJ	1-0AA0	205	
560	39000	1450	100	140	560	250	220	106	326	700	65	532	8	650	16	26	4.6	8.2	2LC0131-6AJ	1-0AA0	330	
			140	180	300													5		2LC0131-6AJ	1-0AA0	330
			180	200	320													5.1		2LC0131-6AJ	1-0AA0	340
630	52000	1280	100	140	630	250	240	106	346	785	60	602	8	725	16	33	7.2	13.8	2LC0131-7AJ	1-0AA0	390	
			140	180	300													7.7		2LC0131-7AJ	1-0AA0	400
			180	220	355													8.4		2LC0131-7AJ	1-0AA0	420
710	84000	1150	110	160	710	290	260	127	387	875	80	675	10	815	18	33	13	26	2LC0131-8AJ	1-0AA0	550	
			160	200	330													14		2LC0131-8AJ	1-0AA0	550
			200	240	385													15		2LC0131-8AJ	1-0AA0	570
800	110000	1000	125	180	800	320	290	127	417	1000	70	765	10	930	16	39	22	45	2LC0131-9AJ	1-0AA0	680	
			180	220	360													23		2LC0131-9AJ	1-0AA0	690
			220	260	420													24.5		2LC0131-9AJ	1-0AA0	710

- ØD1:
- Without finished bore up to size 500, from size 560 for 1st diameter range D1 – Without order codes **1**
  - Without finished bore from size 560 for 2nd diameter range D1 – Without order codes **2**
  - Without finished bore from size 560 for 3rd diameter range D1 – Without order codes **3**
  - With finished bore – With order codes for diameter and tolerance (product code without **-Z**) **9**

From size 560 bore D1 is provided with a recess of  $D = +1$  mm halfway along the hub.  $V \approx 1/3$  NL

Weight and mass moments of inertia apply to maximum bore diameters.

The product code applies to standard buffers of 80 ShoreA; the product code for alternative buffer types is available on request.

# FLENDER Standard Couplings Flexible Couplings – RUPEX Series

Type RFS in steel

## Selection and ordering data

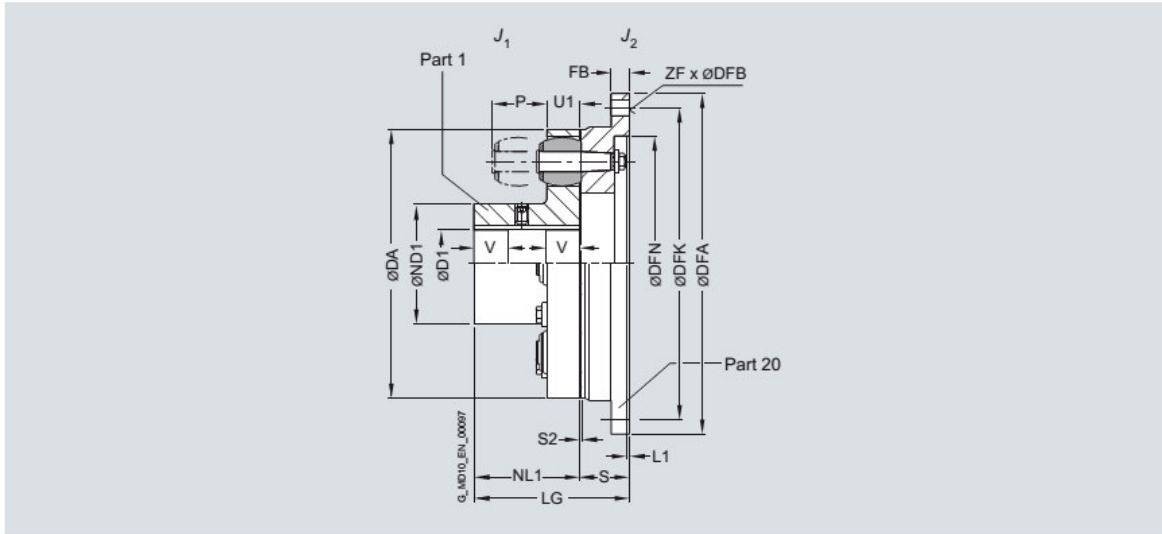

For dimensions U1, P and S2, see type RWS.

Size	Rated torque buffer 80 ShoreA $T_{KN}$ Nm	Speed $n_{Kmax}$ rpm	Dimensions in mm Bore with keyway to DIN 6885										Flange connection				Mass moment of inertia		Product code Order codes for bore diameters and tolerances are specified in catalog section 3	Weight $m$ kg	
			D1 min.	DA max.	ND1	NL1	S	LG	DFA h8	FB	DFN H7	L1	DFK	ZF	DFB	$J_1$ kgm <sup>2</sup>	$J_2$ kgm <sup>2</sup>				
105	200	10000	-	32	105	53	45	26	71	158	10		142	6	9	0.001	0.005	2LC0130-1AK ■ 1-0AA0	2.3		
125	350	9000	-	42	125	65	50	31	81	180	13		160	6	11	0.003	0.012	2LC0130-2AK ■ 1-0AA0	4.2		
144	500	7800	-	50	144	76	55	31	86	200	13		180	7	11	0.004	0.018	2LC0130-3AK ■ 1-0AA0	5.0		
162	750	6900	-	55	162	85	60	37.5	97.5	220	13		200	8	11	0.007	0.032	2LC0130-4AK ■ 1-0AA0	7.3		
178	950	6300	-	70	178	102	70	37.5	107.5	248	16		224	8	14	0.014	0.055	2LC0130-5AK ■ 1-0AA0	10.0		
198	1300	5600	-	80	198	120	80	37.5	117.5	274	16		250	8	14	0.022	0.080	2LC0130-6AK ■ 1-0AA0	13		
228	2200	4900	-	85	228	129	90	45.5	135.5	314	20		282	8	18	0.038	0.18	2LC0130-7AK ■ 1-0AA0	20		
252	2750	4400	-	100	252	150	100	45.5	145.5	344	20		312	8	18	0.07	0.26	2LC0130-8AK ■ 1-0AA0	25		
285	4300	3900	48	110	285	164	110	55.5	165.5	380	22		348	9	18	0.13	0.46	2LC0131-0AK ■ 1-0AA0	38		
320	5500	3500	55	125	320	180	125	55.5	175.5	430	25		390	9	22	0.23	0.76	2LC0131-1AK ■ 1-0AA0	50		
360	7800	3100	65	135	360	200	140	70.5	210.5	480	25		440	10	22	0.41	1.4	2LC0131-2AK ■ 1-0AA0	76		
400	12500	2800	75	150	400	230	160	74.5	234.5	520	50	380	4	480	10	22	0.92	1.8	2LC0131-3AK ■ 1-0AA0	125	
450	18500	2500	85	170	450	260	180	85.5	265.5	575	45	428	6	528	12	26	1.7	3.2	2LC0131-4AK ■ 1-0AA0	175	
500	25000	2200	95	190	500	290	200	85.5	285.5	620	45	475	6	570	12	26	2.8	4.3	2LC0131-5AK ■ 1-0AA0	210	
560	39000	2000	100	165	560	250	220	106	326	700	65	532	8	650	16	26	4.8	8.2	2LC0131-6AK ■ 1-0AA0	330	
			165	200	300													5.2		2LC0131-6AK ■ 1-0AA0	340
			200	210	320													5.4		2LC0131-6AK ■ 1-0AA0	340
630	52000	1800	100	165	630	250	240	106	346	785	60	602	8	725	16	33	7.6	13.8	2LC0131-7AK ■ 1-0AA0	390	
			165	200	300													7.9		2LC0131-7AK ■ 1-0AA0	400
			200	235	355													8.7		2LC0131-7AK ■ 1-0AA0	420
710	84000	1600	110	190	710	290	260	127	387	875	80	675	10	815	18	33	14.4	26	2LC0131-8AK ■ 1-0AA0	550	
			190	220	330													14.6		2LC0131-8AK ■ 1-0AA0	560
			220	250	385													15.9		2LC0131-8AK ■ 1-0AA0	580
800	110000	1400	125	210	800	320	290	127	417	1000	70	765	10	930	16	39	23.1	45	2LC0131-9AK ■ 1-0AA0	690	
			210	240	360													23.3		2LC0131-9AK ■ 1-0AA0	710
			240	280	420													25.7		2LC0131-9AK ■ 1-0AA0	730

- ØD1:
- Without finished bore up to size 500, from size 560 for 1st diameter range D1 – Without order codes **1**
  - Without finished bore from size 560 for 2nd diameter range D1 – Without order codes **2**
  - Without finished bore from size 560 for 3rd diameter range D1 – Without order codes **3**
  - With finished bore – With order codes for diameter and tolerance (product code without **-Z**) **9**

From size 560 bore D1 is provided with a recess of  $D = +1$  mm halfway along the hub.  $V \approx 1/3$  NL

Weight and mass moments of inertia apply to maximum bore diameters.

The product code applies to standard buffers of 80 ShoreA; the product code for alternative buffer types is available on request.

# FLENDER Standard Couplings Flexible Couplings – RUPEX Series

Type RWB with brake disk to DIN 15432

## Selection and ordering data

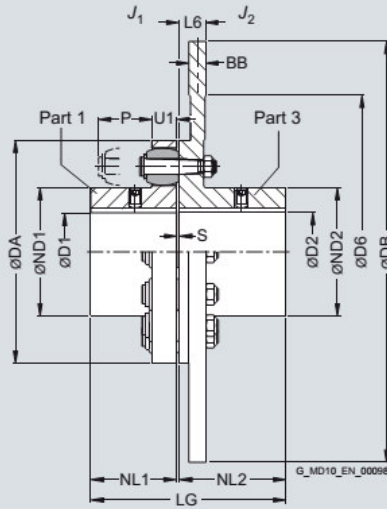

8

Size	Rated torque buffer 80 ShoreA $T_{KN}$ Nm	Dimensions in mm														Brake disk		Product code Plain text specification <b>DB</b> ; <b>BB</b> ; <b>D6</b> ; <b>NL2</b> required for order code <b>P0Y</b> Order codes for bore diameters and tolerances are specified in catalog section 3																		
		Bore with keyway to DIN 6885		D2		DA		ND1		ND2		NL1		NL2		S			U1		P		LG		DB		D6		BB		L6					
		min.	max.	min.	max.																															
144	500	-	45	-	45	144	76	84	55	219	3	16	35	277	500	315	175	30	34																	2LC0130-3AE ■ ■ -0ZA0 P0Y
162	750	-	50	-	50	162	85	92	60	219	3.5	20	40	282.5	560	315	175	30	34																	2LC0130-4AE ■ ■ -0ZA0 P0Y
178	950	-	60	-	60	178	102	108	70	219	3.5	20	40	292.5	560	355	200	30	34																	2LC0130-5AE ■ ■ -0ZA0 P0Y
198	1300	-	70	-	70	198	120	128	80	219	3.5	20	40	302.5	560	355	200	30	34																	2LC0130-6AE ■ ■ -0ZA0 P0Y
228	2200	-	80	-	80	228	129	140	90	219	3.5	26	50	312.5	800	450	250	30	34																	2LC0130-7AE ■ ■ -0ZA0 P0Y
252	2750	-	90	38	100	252	150	160	100	219	3.5	26	50	322.5	800	500	280	30	34																	2LC0130-8AE ■ ■ -0ZA0 P0Y
285	4300	48	100	48	110	285	164	175	110	219	4.5	32	60	333.5	800	560	310	30	34																	2LC0131-0AE ■ ■ -0ZA0 P0Y
320	5500	55	110	55	120	320	180	192	125	219	4.5	32	60	348.5	1000	630	350	30	34																	2LC0131-1AE ■ ■ -0ZA0 P0Y

- |      |  |   |
|------|--|---|
| ØD1: | • Without finished bore – Without order codes  | 1 |
|      | • With finished bore – With order codes for diameter and tolerance (product code without <b>-Z</b> ) | 9 |
| ØD2: | • Without finished bore – Without order codes  | 1 |
|      | • With finished bore – With order codes for diameter and tolerance (product code without <b>-Z</b> ) | 9 |

## FLENDER Standard Couplings Flexible Couplings – RUPEX Series

Type RWB with brake disk to DIN 15432

### Brake disk diameter DB in accordance with customer specification.

Additional sizes are available on request. Further dimensions for part 3 on request.

Maximum speed in rpm:

$$n_{kmax} = 1146/DB \quad DB \text{ in m}$$

Observe maximum speed of type RWN!

Mass moments of inertia and weights can be sufficiently precisely determined as follows:

- Mass moments of inertia in  $\text{kgm}^2$ :  
 $J_1 = J_1$  from type RWN  
 $J_2 = J_2$  from type RWN +  $710 \cdot BB \cdot DB^4$  BB and DB in m
- Weight in kg:  
 $m = m$  from type RWN +  $5700 \cdot BB \cdot DB^2$  BB and DB in m

Ordering example:

RUPEX RWB coupling, size 252,

Part 1: Bore D1 = 48H7 mm, keyway to DIN 6885-1 and set screw,

Part 3: Brake disk DB = 630; BB = 30 mm; D6 = 350 mm, bore 42H7 mm, keyway to DIN 6885-1 P9 and set screw.

Hub reduced to NL2 = 200 mm

Coupling micro-balanced G6.3 at 1500 rpm in accordance with the half parallel key standard.

Mass moment of inertia:

$$J_1 = 0.07 \text{ kgm}^2,$$

$$J_2 = 0.12 \text{ kgm}^2 + 3.3 \text{ kgm}^2 = 3.42 \text{ kgm}^2$$

Weight:

$$m = 26.3 \text{ kg} + 68 \text{ kg} = 94.3 \text{ kg}$$

Product code:

**2LC0130-8AE99-0ZA0-Z**

**L1B+MOX+POY+W02**

plain text to P0Y:

**DB = 630 mm; BB = 30 mm;**

**D6 = 350 mm; NL2 = 200 mm**

The product code applies to standard buffers of 80 ShoreA; the product code for alternative buffer types is available on request.

# FLENDER Standard Couplings Flexible Couplings – RUPEX Series

Type RBS with brake disk to DIN 15432  
Sizes 144 to 360

## Selection and ordering data

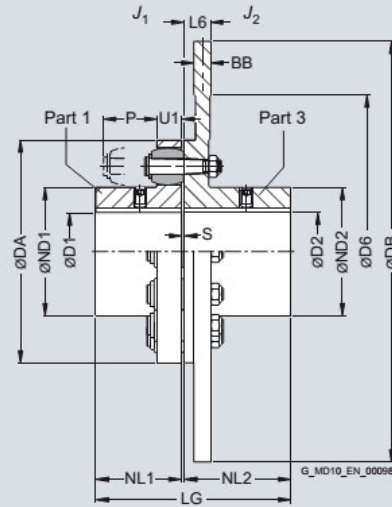

8

Size	Rated torque buffer 80 ShoreA $T_{KN}$ Nm	Dimensions in mm														Brake disk		Product code Plain text specification <b>DB</b> ; <b>BB</b> ; <b>D6</b> ; <b>NL2</b> required for order code <b>P0Y</b> Order codes for bore diameters and tolerances are specified in catalog section 3							
		Bore with keyway to DIN 6885		D1		D2		DA		ND1		ND2		NL1		NL2			S	U1	P	LG	DB	D6	BB
		min.	max.	min.	max.	min.	max.	min.	max.	min.	max.	min.	max.	min.	max.	min.	max.				max.	min.			
144	500	-	50	-	45	144	76	84	55	219	3	16	35	277	315	175	30	34							<b>2LC0130-3AH</b> ■ ■ ■ <b>-0ZA0</b> <b>P0Y</b>
162	750	-	55	-	50	162	85	92	60	219	3.5	20	40	282.5	315	175	30	34							<b>2LC0130-4AH</b> ■ ■ ■ <b>-0ZA0</b> <b>P0Y</b>
178	950	-	70	-	60	178	102	108	70	219	3.5	20	40	292.5	355	200	30	34							<b>2LC0130-5AH</b> ■ ■ ■ <b>-0ZA0</b> <b>P0Y</b>
198	1300	-	80	-	70	198	120	128	80	219	3.5	20	40	302.5	355	200	30	34							<b>2LC0130-6AH</b> ■ ■ ■ <b>-0ZA0</b> <b>P0Y</b>
228	2200	-	85	-	80	228	129	140	90	219	3.5	26	50	312.5	450	250	30	34							<b>2LC0130-7AH</b> ■ ■ ■ <b>-0ZA0</b> <b>P0Y</b>
252	2750	-	100	38	100	252	150	160	100	219	3.5	26	50	322.5	500	280	30	34							<b>2LC0130-8AH</b> ■ ■ ■ <b>-0ZA0</b> <b>P0Y</b>
285	4300	48	110	48	120	285	164	175	110	219	4.5	32	60	333.5	560	310	30	34							<b>2LC0131-0AH</b> ■ ■ ■ <b>-0ZA0</b> <b>P0Y</b>
320	5500	55	125	55	130	320	180	192	125	219	4.5	32	60	348.5	630	350	30	34							<b>2LC0131-1AH</b> ■ ■ ■ <b>-0ZA0</b> <b>P0Y</b>
360	7800	65	135	65	140	360	200	210	140	221	4.5	42	75	365.5	710	390	30	34							<b>2LC0131-2AE</b> ■ ■ ■ <b>-0ZA0</b> <b>P0Y</b>
ØD1:		<ul style="list-style-type: none"> <li>Without finished bore – Without order codes</li> <li>With finished bore – With order codes for diameter and tolerance (product code without <b>-Z</b>)</li> </ul>																				1 9			
ØD2:		<ul style="list-style-type: none"> <li>Without finished bore – Without order codes</li> <li>With finished bore – With order codes for diameter and tolerance (product code without <b>-Z</b>)</li> </ul>																				1 9			

## FLENDER Standard Couplings Flexible Couplings – RUPEX Series

Type RBS with brake disk to DIN 15432  
Sizes 144 to 360

### Brake disk diameter DB in accordance with customer specification.

Additional sizes are available on request. Further dimensions for part 3 on request.

Maximum speed in rpm:

$$n_{kmax} = 1528/DB \quad DB \text{ in m}$$

Observe maximum speed of type RWS!

Mass moments of inertia and weights can be sufficiently precisely determined as follows:

- Mass moments of inertia in  $\text{kgm}^2$ :  
 $J_1 = J_1$  from type RWS  
 $J_2 = J_2$  from type RWS +  $770 \cdot BB \cdot DB^4$   $BB$  and  $DB$  in m
- Weight in kg:  
 $m = m$  from type RWS +  $6160 \cdot BB \cdot DB^2$   $BB$  and  $DB$  in m

Ordering example:

RUPEX RBS coupling, size 252,

Part 1: Bore D1 = 48H7 mm, keyway to DIN 6885-1 and set screw,

Part 3: Brake disk DB = 630 x BB = 30 mm, D6 = 350 mm, bore 42H7 mm, keyway to DIN 6885-1 P9 and set screw.

Hub reduced to NL2 = 200 mm

Coupling micro-balanced G6.3 at 1500 rpm in accordance with the half parallel key standard.

Mass moment of inertia:

$$J_1 = 0.07 \text{ kgm}^2, J_2 = 0.12 \text{ kgm}^2 + 3.6 \text{ kgm}^2 = 3.72 \text{ kgm}^2$$

Weight:

$$m = 25.8 \text{ kg} + 73 \text{ kg} = 98.8 \text{ kg}$$

Product code:

**2LC0130-8AH99-OZA0-Z**

**L1B+MOX+POY+W02**

plain text to POY:

**DB = 630 mm; BB = 30 mm;**

**D6 = 350 mm; NL2 = 200 mm**

The product code applies to standard buffers of 80 ShoreA; the product code for alternative buffer types is available on request.

# FLENDER Standard Couplings Flexible Couplings – RUPEX Series

Type RBS with brake disk to DIN 15432  
Sizes 400 to 1000

## Selection and ordering data

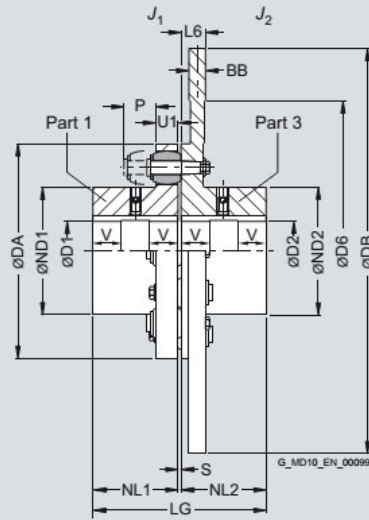

8

Size	Rated torque buffer 80 ShoreA $T_{KN}$ Nm	Dimensions in mm Bore with keyway to DIN 6885											Brake disk			Product code Plain text specification <b>DB</b> ; <b>BB</b> ; <b>D6</b> ; <b>NL2</b> required for order code <b>P0Y</b> Order codes for bore diameters and tolerances are specified in catalog section 3		
		D1		D2		DA	ND1	ND2	NL1	NL2	S	U1	P	LG	D6 min.		BB	L6
		min.	max.	min.	max.													
400	12500	75	150	75	150	400	230	230	160	225	4.5	42	75	389.5	440	30	40	2LC0131-3AH ■ ■ -OZA0 P0Y
450	18500	85	170	85	170	450	260	260	180	225	5.5	52	90	410.5	500	30	40	2LC0131-4AH ■ ■ -OZA0 P0Y
500	25000	95	190	95	190	500	290	290	200	225	5.5	52	90	430.5	500	30	40	2LC0131-5AH ■ ■ -OZA0 P0Y
560	39000	100	165	100	210	560	250	320	220	225	6	68	120	451	560	30	40	2LC0131-6AH ■ ■ -OZA0 P0Y
		165	200				300											2LC0131-6AH ■ ■ -OZA0 P0Y
		200	210				320											2LC0131-6AH ■ ■ -OZA0 P0Y
630	52000	100	165	100	235	630	250	355	240	240	6	68	120	486	630	30	55	2LC0131-7AH ■ ■ -OZA0 P0Y
		165	200				300											2LC0131-7AH ■ ■ -OZA0 P0Y
		200	235				355											2LC0131-7AH ■ ■ -OZA0 P0Y
710	84000	110	190	110	250	710	290	385	260	260	7	80	140	527	710	30	75	2LC0131-8AH ■ ■ -OZA0 P0Y
		190	220				330											2LC0131-8AH ■ ■ -OZA0 P0Y
		220	250				385											2LC0131-8AH ■ ■ -OZA0 P0Y
800	110000	125	210	125	280	800	320	420	290	290	7	80	140	587	800	30	75	2LC0132-0AH ■ ■ -OZA0 P0Y
		210	240				360											2LC0132-0AH ■ ■ -OZA0 P0Y
		240	280				420											2LC0132-0AH ■ ■ -OZA0 P0Y

- |      |   |   |
|------|---|---|
| ØD1: | • Without finished bore up to size 500, from size 560 for 1st diameter range D1 – Without order codes | 1 |
|      | • Without finished bore from size 560 for 2nd diameter range D1 – Without order codes                 | 2 |
|      | • Without finished bore from size 560 for 3rd diameter range D1 – Without order codes                 | 3 |
|      | • With finished bore – With order codes for diameter and tolerance (product code without -Z)          | 9 |
| ØD2: | • Without finished bore up to size 500, from size 560 for 1st diameter range D1 – Without order codes | 1 |
|      | • Without finished bore from size 560 for 2nd diameter range D2 – Without order codes                 | 2 |
|      | • Without finished bore from size 560 for 3rd diameter range D2 – Without order codes                 | 3 |
|      | • With finished bore – With order codes for diameter and tolerance (product code without -Z)          | 9 |



# FLENDER Standard Couplings

## Flexible Couplings – RUPEX Series

Type RBS with brake disk to DIN 15432  
Sizes 400 to 1000

Size	Rated torque buffer 80 ShoreA $T_{KN}$ Nm	Dimensions in mm														Brake disk	Product code Plain text specification <b>DB</b> ; <b>BB</b> ; <b>D6</b> ; <b>NL2</b> required for order code <b>P0Y</b> Order codes for bore diameters and tolerances are specified in catalog section 3	
		Bore with keyway to DIN 6885		D2		DA	ND1	ND2	NL1	NL2	S	U1	P	LG	D6 min.			BB
		D1 min.	D1 max.	D2 min.	D2 max.													
<b>900</b>	150000	140	210	140	310	900	320	465	320	–	7.5	90	160	647.5	900	30	75	<b>2LC0132-1AH</b> ■ ■ ■ - <b>OZA0</b> <b>P0Y</b>
		210	240				360											<b>2LC0132-1AH</b> ■ ■ ■ - <b>OZA0</b> <b>P0Y</b>
		240	280				425											<b>2LC0132-1AH</b> ■ ■ ■ - <b>OZA0</b> <b>P0Y</b>
		280	310				465											<b>2LC0132-1AH</b> ■ ■ ■ - <b>OZA0</b> <b>P0Y</b>
<b>1000</b>	195000	150	230	150	340	1000	355	515	350	–	7.5	90	160	707.5	1000	30	75	<b>2LC0132-2AH</b> ■ ■ ■ - <b>OZA0</b> <b>P0Y</b>
		230	260				395											<b>2LC0132-2AH</b> ■ ■ ■ - <b>OZA0</b> <b>P0Y</b>
		260	300				460											<b>2LC0132-2AH</b> ■ ■ ■ - <b>OZA0</b> <b>P0Y</b>
		300	340				515											<b>2LC0132-2AH</b> ■ ■ ■ - <b>OZA0</b> <b>P0Y</b>

∅D1:	• Without finished bore up to size 500, from size 560 for 1st diameter range D1 – Without order codes	1
	• Without finished bore from size 560 for 2nd diameter range D1 – Without order codes	2
	• Without finished bore from size 560 for 3rd diameter range D1 – Without order codes	3
	• Without finished bore from size 900 for 4th diameter range D1 – Without order codes	4
	• With finished bore – With order codes for diameter and tolerance (product code without <b>-Z</b> )	9
∅D2:	• Without finished bore up to size 500, from size 560 for 1st diameter range D1 – Without order codes	1
	• Without finished bore from size 560 for 2nd diameter range D2 – Without order codes	2
	• Without finished bore from size 560 for 3rd diameter range D2 – Without order codes	3
	• Without finished bore from size 900 for 4th diameter range D2 – Without order codes	4
	• With finished bore – With order codes for diameter and tolerance (product code without <b>-Z</b> )	9

From size 560 bore D1 is provided with a recess of  $D = +1$  mm halfway along the hub.  
 $V \approx 1/3$  NL

### Brake disk diameter DB in accordance with customer specification.

Additional sizes are available on request. Further dimensions for part 3 on request.

Maximum speed in rpm:

$$n_{Kmax} = 1528/DB \quad DB \text{ in m}$$

Observe maximum speed of type RWS!

Mass moments of inertia and weights can be sufficiently precisely determined as follows:

- Mass moments of inertia in  $\text{kgm}^2$ :  
 $J_1 = J_1$  from type RWS  
 $J_2 = J_2$  from type RWS +  $770 \cdot BB \cdot DB^4$  BB and DB in m
- Weight in kg:  
 $m = m$  from type RWS +  $6160 \cdot BB \cdot DB^2$  BB and DB in m

Ordering example:

RUPEX RBS coupling, size 450,

Part 1: Bore D1 = 130H7 mm, keyway to DIN 6885-1 and set screw,

Part 3: Brake disk DB = 900; BB = 30 mm; D6 = 500 mm; bore 120H7 mm, keyway to DIN 6885-1 P9 and set screw.

Coupling micro-balanced G6.3 at 1500 rpm in accordance with the half parallel key standard.

Mass moment of inertia:

$$J_1 = 1.74 \text{ kgm}^2$$

$$J_2 = 1.74 \text{ kgm}^2 + 15 \text{ kgm}^2 = 16.74 \text{ kgm}^2$$

Weight:

$$m = 25.8 \text{ kg} + 149 \text{ kg} = 174.8 \text{ kg}$$

Product code:

**2LC0131-4AH99-OZA0-Z**

**L1U+M1S+P0Y+W02**

plain text to P0Y:

**DB = 900 mm; BB = 30 mm;**

**D6 = 500 mm; NL2 = 322 mm**

The product code applies to standard buffers of 80 ShoreA; the product code for alternative buffer types is available on request.

# FLENDER Standard Couplings Flexible Couplings – RUPEX Series

Type RWB with brake drum to DIN 15431

## Selection and ordering data

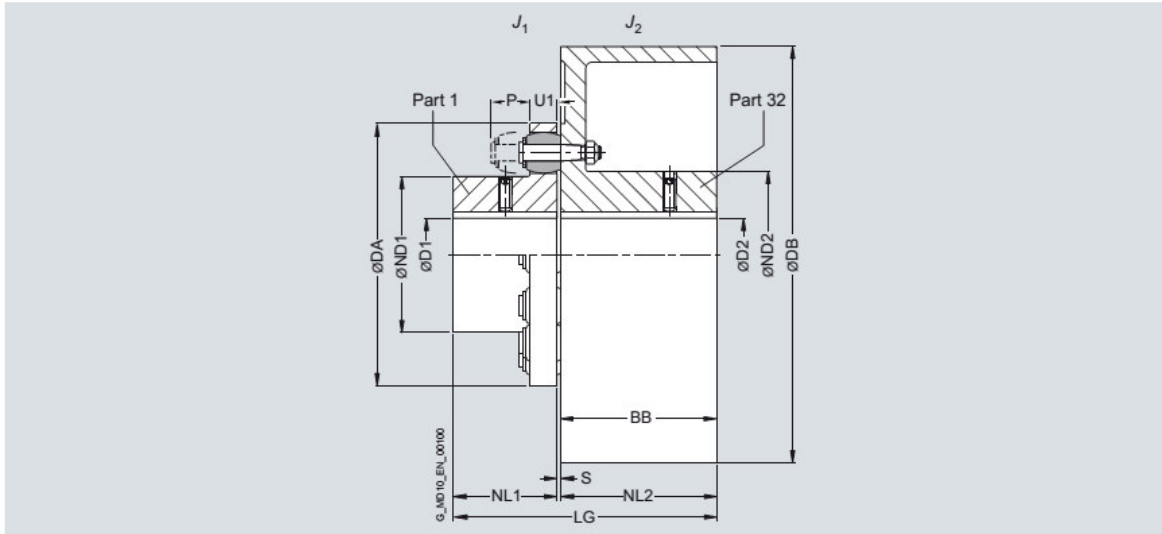

For dimensions U1 and P, see type RWN.

Size	Rated torque buffer 80 ShoreA $T_{KN}$ Nm	Speed $n_{kmax}$ rpm	Dimensions in mm Bore with keyway to DIN 6885											Mass moment of inertia		Product code Order codes for bore diameters and tolerances are specified in catalog section 3	Weight $m$ kg		
			D1		D2		DA	ND1	ND2	NL1	NL2/ S	DB	LG	$J_1$	$J_2$				
			min.	max.	min.	max.													
144	500	3400	-	45	-	55	144	76	84	55	75	3	200	133	0.004	0.04	<b>2LC0130-3AC</b>	<b>■ ■ -0BA0</b>	9.5
162	750	2750	-	50	-	60	162	85	92	60	95	3.5	250	158.5	0.007	0.11	<b>2LC0130-4AC</b>	<b>■ ■ -0CA0</b>	17
178	950	2750	-	60	-	70	178	102	108	70	95	3.5	250	168.5	0.014	0.12	<b>2LC0130-5AC</b>	<b>■ ■ -0CA0</b>	20
		2150	-	-	-	-	-	-	-	-	118	-	-	315	191.5	0.31	<b>2LC0130-5AC</b>	<b>■ ■ -0DA0</b>	28
198	1300	2750	-	70	-	80	198	120	128	80	95	3.5	250	178.5	0.022	0.13	<b>2LC0130-6AC</b>	<b>■ ■ -0CA0</b>	24
		2150	-	-	-	-	-	-	-	-	118	-	-	315	201.5	0.32	<b>2LC0130-6AC</b>	<b>■ ■ -0DA0</b>	32
228	2200	1700	-	80	-	90	228	129	140	90	150	3.5	400	243.5	0.038	1.0	<b>2LC0130-7AC</b>	<b>■ ■ -0EA0</b>	54
252	2750	1700	-	90	38	100	252	150	160	100	150	3.5	400	253.5	0.07	1.0	<b>2LC0130-8AC</b>	<b>■ ■ -0EA0</b>	63
		1400	-	-	-	-	-	-	-	-	190	-	-	500	293.5	2.8	<b>2LC0130-8AC</b>	<b>■ ■ -0FA0</b>	93
285	4300	1400	48	100	48	110	285	164	175	110	190	4.5	500	304.5	0.13	2.8	<b>2LC0131-0AC</b>	<b>■ ■ -0FA0</b>	104
		1100	-	-	-	-	-	-	-	-	236	-	-	630	350.5	7.8	<b>2LC0131-0AC</b>	<b>■ ■ -0GA0</b>	157
320	5500	1100	55	110	55	120	320	180	192	125	236	4.5	630	365.5	0.23	7.9	<b>2LC0131-1AC</b>	<b>■ ■ -0GA0</b>	172
		950	-	-	-	-	-	-	-	-	265	-	-	710	394.5	13.9	<b>2LC0131-1AC</b>	<b>■ ■ -0HA0</b>	217
360	7800	1100	65	120	65	130	360	200	210	140	236	4.5	630	380.5	0.41	8.1	<b>2LC0131-2AC</b>	<b>■ ■ -0GA0</b>	191
		950	-	-	-	-	-	-	-	-	265	-	-	710	409.5	14.0	<b>2LC0131-2AC</b>	<b>■ ■ -0HA0</b>	236

- ∅D1:
  - Without finished bore – Without order codes
  - With finished bore – With order codes for diameter and tolerance (product code without **-Z**)
- ∅D2:
  - Without finished bore – Without order codes
  - With finished bore – With order codes for diameter and tolerance (product code without **-Z**)

Weight and mass moments of inertia apply to maximum bore diameters.

Ordering example:  
RUPEX RWB coupling, size 252,  
Part 1: Bore 48H7 mm, keyway to DIN 6885-1 and set screw,  
Part 3: 500 x 190, bore 42H7 mm, keyway to DIN 6885-1 P9 and set screw.

Coupling micro-balanced G6.3 at 1500 rpm in accordance with the half parallel key standard.

Product code:  
**2LC0130-8AC99-0FA0-Z**  
**L1B+M0X+W02**

The product code applies to standard buffers of 80 ShoreA; the product code for alternative buffer types is available on request.

# FLENDER Standard Couplings Flexible Couplings – RUPEX Series

Type RBS with brake drum to DIN 15431

## Selection and ordering data

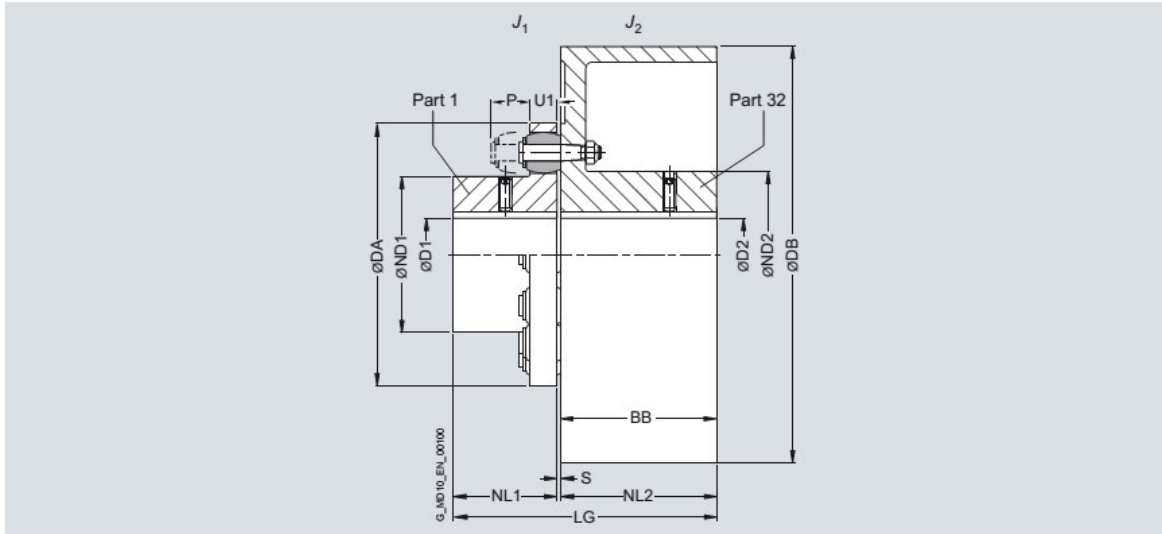

For dimensions U1 and P, see type RWS

Size	Rated torque buffer 80 ShoreA $T_{KN}$ Nm	Speed $n_{Kmax}$ rpm	Dimensions in mm Bore with keyway to DIN 6885											Mass moment of inertia		Product code Order codes for bore diameters and tolerances are specified in catalog section 3	Weight  m kg		
			D1		D2		DA	ND1	ND2	NL1	NL2	S	DB	LG	$J_1$			$J_2$	
			min.	max.	min.	max.					BB				kgm <sup>2</sup>			kgm <sup>2</sup>	
144	500	5000	-	50	-	60	144	76	84	55	75	3	200	133	0.004	0.04	2LC0130-3AD	■ ■ -0BA0	10
162	750	5000	-	55	-	65	162	85	92	60	95	3.5	250	158.5	0.007	0.13	2LC0130-4AD	■ ■ -0CA0	18
178	950	4900	-	70	-	75	178	102	108	70	95	3.5	250	168.5	0.014	0.13	2LC0130-5AD	■ ■ -0CA0	22
		4350									118		315	191.5	0.34	0.34	2LC0130-5AD	■ ■ -0DA0	30
198	1300	4600	-	80	-	85	198	120	128	80	95	3.5	250	178.5	0.022	0.14	2LC0130-6AD	■ ■ -0CA0	26
		4350									118		315	201.5	0.35	0.35	2LC0130-6AD	■ ■ -0DA0	35
228	2200	3400	-	85	-	95	228	129	140	90	150	3.5	400	243.5	0.038	1.1	2LC0130-7AD	■ ■ -0EA0	60
252	2750	3400	-	100	38	110	252	150	160	100	150	3.5	400	253.5	0.067	1.1	2LC0130-8AD	■ ■ -0EA0	68
		2750				100					190		500	293.5	3.1	3.1	2LC0130-8AD	■ ■ -0FA0	103
285	4300	2750	48	110	48	110	285	164	175	110	190	4.5	500	304.5	0.13	3.1	2LC0131-0AD	■ ■ -0FA0	115
		2150									236		630	350.5	8.5	8.5	2LC0131-0AD	■ ■ -0GA0	171
320	5500	2150	55	125	55	125	320	180	192	125	236	4.5	630	365.5	0.23	8.6	2LC0131-1AD	■ ■ -0GA0	185
		1900									265		710	394.5	14.8	14.8	2LC0131-1AD	■ ■ -0HA0	230
360	7800	2150	65	135	65	135	360	200	210	140	236	4.5	630	380.5	0.41	8.9	2LC0131-2AD	■ ■ -0GA0	210
		1900									265		710	409.5	15.1	15.1	2LC0131-2AD	■ ■ -0HA0	255

- ØD1:
  - Without finished bore – Without order codes
  - With finished bore – With order codes for diameter and tolerance (product code without -Z)
- ØD2:
  - Without finished bore – Without order codes
  - With finished bore – With order codes for diameter and tolerance (product code without -Z)

Weight and mass moments of inertia apply to maximum bore diameters.

Ordering example:  
 RUPEX RBS coupling, size 252,  
 Part 1: Bore 48H7 mm, keyway to DIN 6885-1 and set screw,  
 Part 3: 500 x 190, bore 42H7 mm, keyway to DIN 6885-1 P9 and set screw.

Coupling micro-balanced.

Product code:  
**2LC0130-8AD99-0FA0-Z**  
**L1B+M0X+W02**

The product code applies to standard buffers of 80 ShoreA; the product code for alternative buffer types is available on request.

# FLENDER Standard Couplings

## Flexible Couplings – RUPEX Series

### Spare and wear parts

#### Selection and ordering data

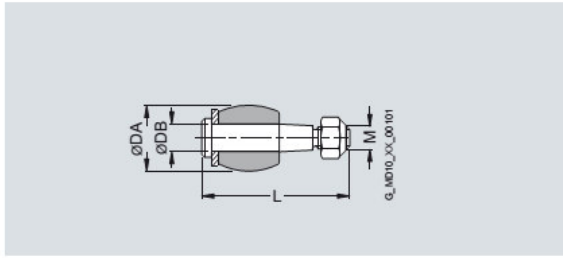

Sizes 105 ... 400

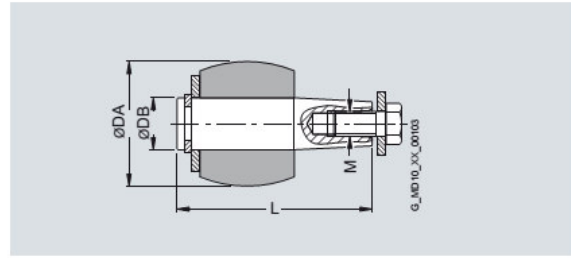

Sizes 710 ... 2000

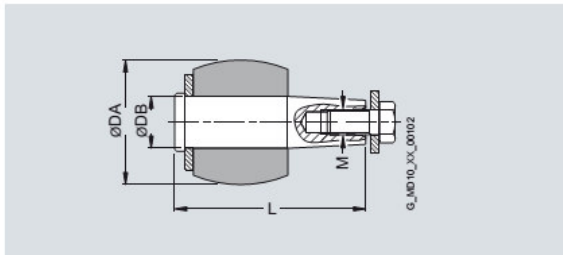

Sizes 450 ... 630

#### Buffers and pins

The buffers of RUPEX couplings are wear parts. The service life depends on the operating conditions.

Size	Identification	Number per set	DA	DB	L	M	Product code for a set of buffers Buffer Perbunan 80 ShoreA	Weight <i>m</i> kg	Product code for a set of pins Pin complete, incl. fasteners	Weight <i>m</i> kg
			mm	mm					mm	
105	105	8	20	8	45	M6	2LC0130-1WA00-0AA0	0.043	2LC0130-1WB00-0AA0	0.14
125	125	8	24	10	53.5	M8	2LC0130-2WA00-0AA0	0.098	2LC0130-2WB00-0AA0	0.28
144	125	10	24	10	53.5	M8	2LC0130-3WA00-0AA0	0.12	2LC0130-3WB00-0AA0	0.35
<sup>*)</sup>	125				59.5				2LC0130-3WB00-0AA0-Z Y99	0.4
162	162	9	30	12	64.5	M10	2LC0130-4WA00-0AA0	0.17	2LC0130-4WB00-0AA0	0.57
<sup>*)</sup>	162				67.5				2LC0130-4WB00-0AA0-Z Y99	0.60
178	162	10	30	12	64.5	M10	2LC0130-5WA00-0AA0	0.19	2LC0130-5WB00-0AA0	0.65
<sup>*)</sup>	162				67.5				2LC0130-5WB00-0AA0-Z Y99	0.67
198	162	12	30	12	64.5	M10	2LC0130-6WA00-0AA0	0.23	2LC0130-6WB00-0AA0	0.76
<sup>*)</sup>	162				67.5				2LC0130-6WB00-0AA0-Z Y99	0.80
228	228	11	40	16	79	M12	2LC0130-7WA00-0AA0	0.42	2LC0130-7WB00-0AA0	1.40
252	228	12	40	16	79	M12	2LC0130-8WA00-0AA0	0.45	2LC0130-8WB00-0AA0	1.50
285	285	11	48	20	98	M16	2LC0131-0WA00-0AA0	0.81	2LC0131-0WB00-0AA0	2.50
320	285	12	48	20	98	M16	2LC0131-1WA00-0AA0	0.88	2LC0131-1WB00-0AA0	2.80
360	360	10	64	25	123	M18	2LC0131-2WA00-0AA0	1.6	2LC0131-2WB00-0AA0	4.4
400	360	14	64	25	123	M18	2LC0131-3WA00-0AA0	2.2	2LC0131-3WB00-0AA0	6.1
450	450	12	78	32	123	M16	2LC0131-4WA00-0AA0	3.5	2LC0131-4WB00-0AA0	11
500	450	14	78	32	123	M16	2LC0131-5WA00-0AA0	4.0	2LC0131-5WB00-0AA0	13
560	560	12	101	42	158	M20	2LC0131-6WA00-0AA0	7.1	2LC0131-6WB00-0AA0	25
630	560	14	101	42	158	M20	2LC0131-7WA00-0AA0	8.3	2LC0131-7WB00-0AA0	29
710	710	14	120	50	185.5	M24	2LC0131-8WA00-0AA0	14	2LC0131-8WB00-0AA0	49
800	710	16	120	50	185.5	M24	2LC0132-0WA00-0AA0	16	2LC0132-0WB00-0AA0	56
900	900	16	136	55	207.5	M24	2LC0132-1WA00-0AA0	24	2LC0132-1WB00-0AA0	71
1000	900	18	136	55	207.5	M24	2LC0132-2WA00-0AA0	27	2LC0132-2WB00-0AA0	80
1120	1120	18	155	60	232.5	M30	2LC0132-3WA00-0AA0	41	2LC0132-3WB00-0AA0	110
1250	1120	20	155	60	232.5	M30	2LC0132-4WA00-0AA0	45	2LC0132-4WB00-0AA0	125
1400	1400	20	175	70	274	M30	2LC0132-5WA00-0AA0	65	2LC0132-5WB00-0AA0	185
1600	1400	24	175	70	274	M30	2LC0132-6WA00-0AA0	78	2LC0132-6WB00-0AA0	225
1800	1800	22	200	80	327	M36	2LC0132-7WA00-0AA0	115	2LC0132-7WB00-0AA0	320
2000	1800	26	200	80	327	M36	2LC0132-8WA00-0AA0	135	2LC0132-8WB00-0AA0	380

\* Only for type RWB with brake disk and type RBS with brake disk.  
Plain text to Y99: "Type RWB/RBS with brake disk"