

# Flexible Couplings BIPEX Series

# 9



9/2	<a href="#">Overview</a>
9/2	<a href="#">Benefits</a>
9/2	<a href="#">Application</a>
9/3	<a href="#">Design</a>
9/4	<a href="#">Technical data</a>
9/5	<b>Type BWN</b>
9/5	<a href="#">Selection and ordering data</a>
9/6	<b>Type BWT</b>
9/6	<a href="#">Selection and ordering data</a>
9/7	<b>Type BNT</b>
9/7	<a href="#">Selection and ordering data</a>
9/8	<b>Spare and wear parts</b>
9/8	<a href="#">Selection and ordering data</a>

# FLENDER Standard Couplings

## Flexible Couplings – BIPEX Series

### General information

#### Overview

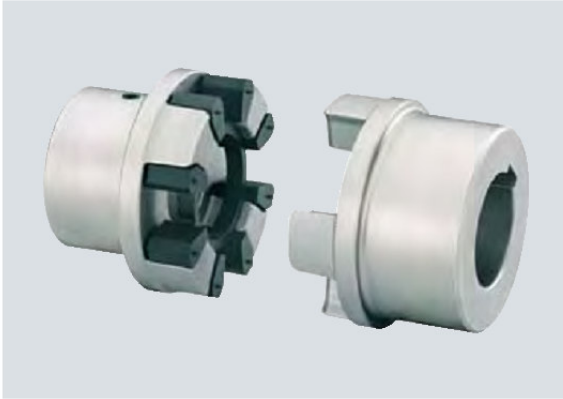

BIPEX couplings are torsionally flexible with low torsional backlash. They are outstanding for their particularly compact construction. BIPEX couplings link machine shafts.

BIPEX couplings are specially suited for electric motor drives which are well aligned and have uniform torque loads.

#### Benefits

BIPEX couplings are suitable for mounting horizontally, vertically or at any desired angle. The coupling parts can be arranged as required on the shaft extensions to be connected.

The cam ring is mounted with low backlash and achieves progressive torsional stiffness, i.e. torsional stiffness increases in proportion to capacity utilization.

The BIPEX coupling is fail-safe, i.e. if the cam ring is worn, the cast cams of the coupling hub provide for emergency operation.

#### Application

The BIPEX coupling is available as a catalog standard in 13 sizes with rated torque of between 13.5 Nm and 3700 Nm. The coupling is suitable for ambient temperatures of between -30 °C and +80 °C.

BIPEX couplings are particularly suited for electric motor drives which have a uniform torque load and are well aligned. BIPEX couplings are frequently fitted and used in motor bell housings.

### Design

BIPEX couplings of types BWN, BWT and BNT each comprise two hub parts connected by a cam ring of elastomer material.

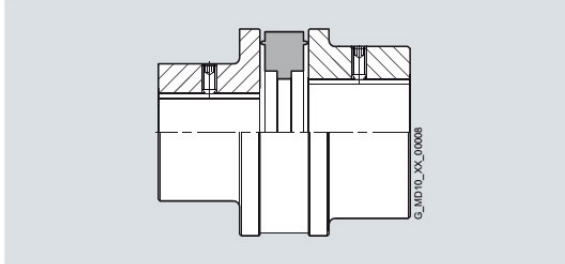

Type BWN

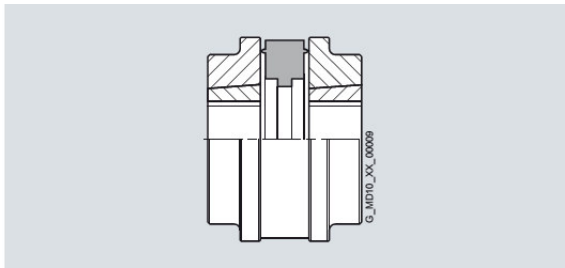

Type BWT

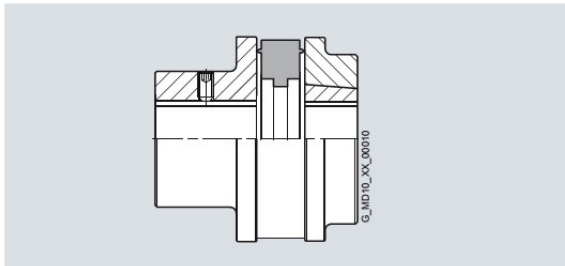

Type BNT

The couplings are inserted during fitting. The hubs are connected to the respective shafts via Taper clamping bushes or finished bores with parallel keyway connection.

BIPEX couplings are positive-locking and torsionally flexible thanks to the polyurethane cam ring. Shaft misalignment will result in deformation of the cam ring.

#### Coupling materials:

Hubs: EN-GJL-250

Cam ring: PU 92 ShoreA -30 °C to +80 °C

#### Types of BIPEX coupling

Type	Description
BWN	Coupling as a shaft-to-shaft connection with drilled and grooved hubs
BWT	Coupling as a shaft-shaft connection with Taper clamping bushes
BNT	Coupling as a shaft-shaft connection with drilled and grooved hubs and a Taper clamping bush

The coupling comprises the following:

- Cam ring
- 2 hub parts with identical cams. The hub parts are designed with a bore and keyway to DIN 6885 or with a taper bore for mounting a Taper clamping bush.

Fitting the clamping bush connects the hub firmly to the machine shaft.

In the case of part 4 the Taper clamping bush is inserted from the machine housing side. If there is insufficient space, the Taper clamping bush cannot be fitted from this side. Besides space for fitting the Taper clamping bush, space for the fitting tool (offset screwdriver) must be taken into consideration. In the case of part 3 the Taper clamping bush is inserted from the shaft end face side. The hub must be fitted before the machines to be connected are pushed together.

# FLENDER Standard Couplings

## Flexible Couplings – BIPEX Series

### General information

#### Technical data

##### Power ratings

Size	Rated torque	Maximum torque	Overload torque	Fatigue torque	Maximum speed	Torsional stiffness at 50 % capacity utilization	Assembly Gap dimension	Permissible shaft misalignment at speed $n = 1500$ rpm <sup>1)</sup>		
	$T_{KN}$ Nm	$T_{Kmax}$ Nm	$T_{KOL}$ Nm	$T_{KW}$	$n_{max}$ rpm	$C_{Tdyn 50\%}$ Nm/rad	$\Delta S$ mm	$\Delta K_a$ mm	$\Delta K_r$ mm	$\Delta K_w$ Degree
43	13.5	40.5	54	2.7	5000	1160	0.5	0.25	0.08	0.1
53	24	72	96	4.8	5000	2100	0.5	0.25	0.09	0.1
62	42	126	168	8.4	5000	3500	0.5	0.25	0.11	0.1
72	75	225	300	15	5000	6100	0.5	0.25	0.12	0.1
84	130	390	520	26	5000	9600	0.5	0.25	0.14	0.1
97	220	660	880	44	5000	15800	1.0	0.5	0.16	0.1
112	360	1080	1440	72	5000	23100	1.0	0.5	0.19	0.1
127	550	1650	2200	110	5000	37000	1.0	0.5	0.21	0.1
142	800	2400	3200	160	4900	57000	1.0	0.5	0.24	0.1
162	1250	3750	5000	250	4200	85000	1.0	0.5	0.27	0.1
182	1750	5250	7000	350	3800	127000	1.0	0.5	0.30	0.1
202	2650	7950	10600	530	3400	171000	1.0	0.5	0.34	0.1
227	3700	11100	14800	740	3000	285000	2.0	1.0	0.38	0.1

##### Torsional stiffness and damping

The values stated in the above table apply to a capacity utilization of 50 %, an excitation amplitude of 10 %  $T_{KN}$  with the frequency 10 Hz and an ambient temperature of 20 °C. Dynamic torsional stiffness is dependent on load and increases in proportion to capacity utilization. The following table shows the correction factors for different nominal loads.

$$C_{Tdyn} = C_{Tdyn 50\%} \cdot FKC$$

Correction factor FKC	Capacity utilization $T_N / T_{KN}$						
	20 %	40 %	50 %	60 %	70 %	80 %	100 %
	0.7	0.9	1.0	1.1	1.25	1.4	1.7

##### The damping coefficient is $\Psi = 1.4$

Furthermore, torsional stiffness and damping depend on the ambient temperature and the frequency and amplitude of the torsional vibration excitation. More precise torsional stiffness and damping parameters on request.

##### Permitted shaft misalignment

The permitted shaft misalignment depends on the operating speed. As the speed increases, lower shaft misalignment values are permitted. The following table shows the correction factors for different speeds.

The maximum speed for the respective coupling size and type must be observed!

$$\Delta K_{perm} = \Delta K_{1500} \cdot FKV$$

Correction factor FKV	Speed in rpm			
	500	1000	1500	3000
	1.20	1.10	1.0	0.70

The axial misalignment may occur dynamically at frequencies up to 10 Hz. For fitting, a maximum gap dimension of  $S_{max.} = S + \Delta S$  and a minimum gap dimension of  $S_{min.} = S - \Delta S$  are permitted.

Shaft misalignments  $\Delta K_a$ ,  $\Delta K_r$  and  $\Delta K_w$  may occur simultaneously.

<sup>1)</sup> The maximum speed of the respective type must be noted. For further information on permissible shaft misalignment, please see the operating instructions.

# FLENDER Standard Couplings Flexible Couplings – BIPEX Series

Type BWN

## Selection and ordering data

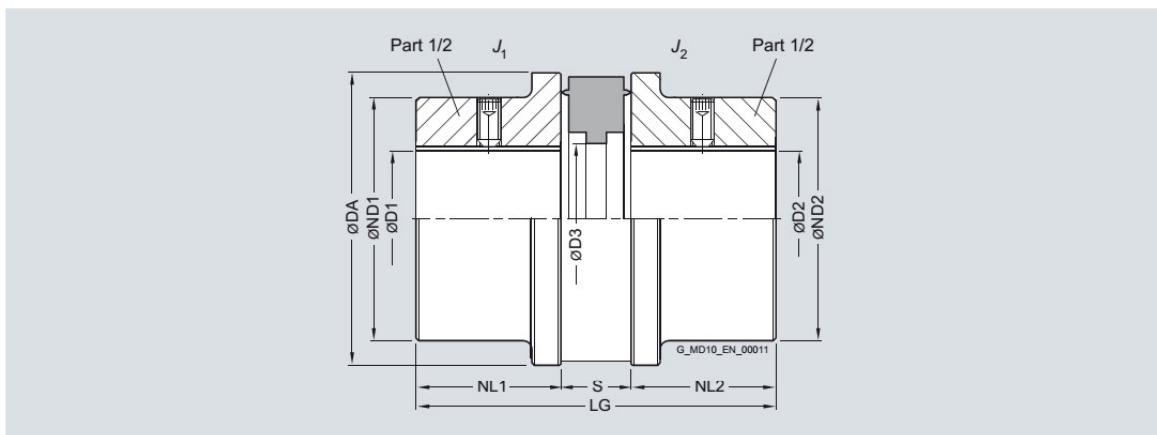

Size	Rated torque $T_{KN}$ Nm	Dimensions in mm							Mass moment of inertia $J_1/J_2$ gm <sup>2</sup>	Product code Order codes for bore diameters and tolerances are specified in catalog section 3	Weight m kg
		Bore with keyway to DIN 6885		ND1/ND2	NL1/NL2	D3	S	LG			
43	13.5	25	43	43	22	21	12	56	0.04	2LC0120-0AA ■ ■ -0AA0	0.36
53	24	30	53	50	25	25	14	64	0.12	2LC0120-1AA ■ ■ -0AA0	0.62
62	42	35	62	58	30	29	16	76	0.26	2LC0120-2AA ■ ■ -0AA0	0.96
72	75	32	72	54	35	36	18	88	0.55	2LC0120-3AA ■ ■ -0AA0	1.4
		42		68					0.65		1.6
84	130	38	84	64	40	40	21	101	0.8	2LC0120-4AA ■ ■ -0AA0	2.1
		48		76					1.1		2.3
97	220	42	97	72	50	48	24	124	1.6	2LC0120-5AA ■ ■ -0AA0	3.3
		50		90					2.2		3.6
112	360	48	112	82	60	54	27	147	3.2	2LC0120-6AA ■ ■ -0AA0	5.0
		60		100					4.8		5.8
127	550	55	127	94	65	61	27	157	6.0	2LC0120-7AA ■ ■ -0AA0	7.3
		65		110					8.0		7.8
142	800	60	142	100	75	70	31	181	10.0	2LC0120-8AA ■ ■ -0AA0	9.8
		75		126					16.0		11.5
162	1250	65	162	110	80	81	36	196	18.0	2LC0121-0AA ■ ■ -0AA0	13.5
		80		134					26.0		15.5
182	1750	75	182	126	90	90	42	222	35.0	2LC0121-1AA ■ ■ -0AA0	19.5
		90		152					46.0		22.0
202	2650	80	202	134	100	100	48	248	55.0	2LC0121-2AA ■ ■ -0AA0	25.0
		100		168					80.0		30.0
227	3700	90	227	150	110	111	54	274	85.0	2LC0121-3AA ■ ■ -0AA0	40.0
		110		180					110.0		45.0

- |      |  |   |
|------|--|---|
| ØD1: | • Without finished bore – Without order codes for diameter and tolerance                     | 1 |
|      | • Without finished bore from size 72 for 2nd diameter range D1 – Without order codes         | 2 |
|      | • With finished bore – With order codes for diameter and tolerance (product code without -Z) | 9 |
| ØD2: | • Without finished bore – Without order codes for diameter and tolerance                     | 1 |
|      | • Without finished bore from size 72 for 2nd diameter range D2 – Without order codes         | 2 |
|      | • With finished bore – With order codes for diameter and tolerance (product code without -Z) | 9 |

Mass moment of inertia J in gm<sup>2</sup>, 1 gm<sup>2</sup> = 0.001 kgm<sup>2</sup>, with reference to one coupling half.

Weight and mass moments of inertia apply to maximum bore diameters.

Ordering example:  
BIPEX BWN coupling, size 43,  
Part 1/2: Bore D1 20H7 mm, with keyway to DIN 6885-1 and set screw,  
Part 1/2: Bore D2 22H7 mm, with keyway to DIN 6885-1 and set screw.

Product code:  
**2LC0120-0AA99-0AA0**  
**LOM+MON**

# FLENDER Standard Couplings Flexible Couplings – BIPEX Series

Type BWT

## Selection and ordering data

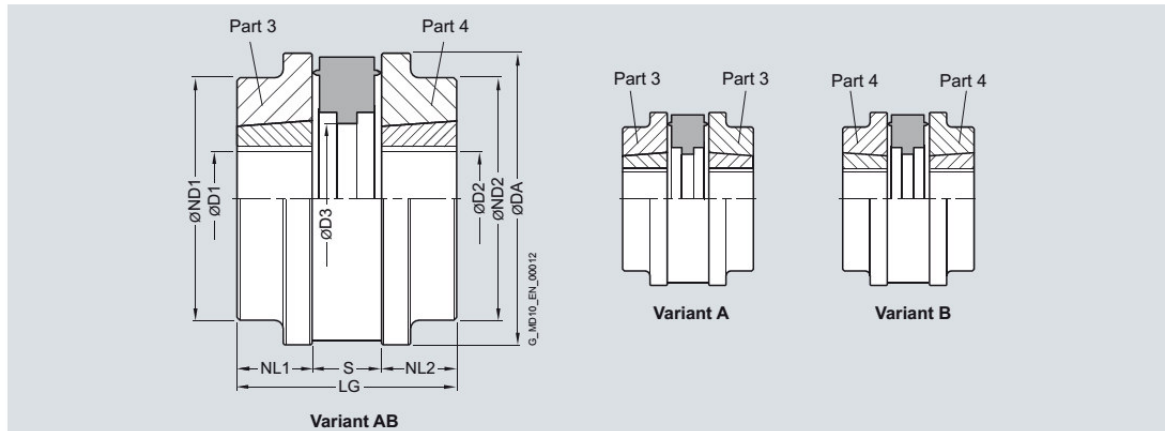

Coupling parts 3 and 4 can be combined as required. In the case of part 3, the Taper clamping bush is fitted from the

shaft end face side, in the case of part 4 from the shaft shoulder side.

Size	Rated torque $T_{KN}$ Nm	Taper clamping bush Size	Dimensions in mm										Mass moment of inertia $J$ gm <sup>2</sup>	Product code Order codes for bore diameters and tolerances are specified in catalog section 3	Weight $m$ kg
			Bore with keyway to DIN 6885-1		DA	ND1 ND2	NL1 NL2	D3	S	LG					
			D1/D2 min.	D1/D2 max.											
62	42	1008	10	25 <sup>1)</sup>	62	58	23	29	16	62	0.22	<b>2LC0120-2A</b> ■■■■-0AA0	0.75		
72	75	1108	10	28 <sup>1)</sup>	72	68	23	36	18	64	0.41	<b>2LC0120-3A</b> ■■■■-0AA0	1.2		
84	130	1210	11	32	84	76	26	40	21	73	0.85	<b>2LC0120-4A</b> ■■■■-0AA0	1.5		
112	360	1610	14	42 <sup>1)</sup>	112	100	26	54	27	79	2.70	<b>2LC0120-6A</b> ■■■■-0AA0	3.2		
142	800	2012	14	50	142	126	33	70	31	97	9.25	<b>2LC0120-8A</b> ■■■■-0AA0	6.2		
182	1750	2517	16	60	182	126	45	90	42	132	27.0	<b>2LC0121-1A</b> ■■■■-0AA0	11.3		
202	2650	3020	25	75	202	168	52	100	48	152	52.5	<b>2LC0121-2A</b> ■■■■-0AA0	15.6		
227	3700	3535	35	90	227	180	90	111	54	134	82.5	<b>2LC0121-3A</b> ■■■■-0AA0	30.0		
Variant:													<b>B</b>		
														<b>C</b>	
														<b>D</b>	
ØD1:														<b>1</b>	
														<b>9</b>	
ØD2:														<b>1</b>	
														<b>9</b>	

Mass moment of inertia  $J$  in gm<sup>2</sup>, 1 gm<sup>2</sup> = 0.001 kgm<sup>2</sup>, with reference to one coupling half.

Weight and mass moments of inertia apply to maximum bore diameters.

Ordering example:  
BIPEX BWT coupling, size 62, variant AB  
Part 3: with Taper clamping bush size 1008, Bore D1 20 mm, with keyway to DIN 6885-1,  
Part 4: with Taper clamping bush size 1008, Bore D2 22 mm, with keyway to DIN 6885-1 and set screw.

Product code:  
**2LC0120-2AD99-0AA0**  
**LOM+MON**

<sup>1)</sup> Maximum bore with shallow keyway, see catalog section 14.

# FLENDER Standard Couplings

## Flexible Couplings – BIPEX Series

Type BNT

## Selection and ordering data

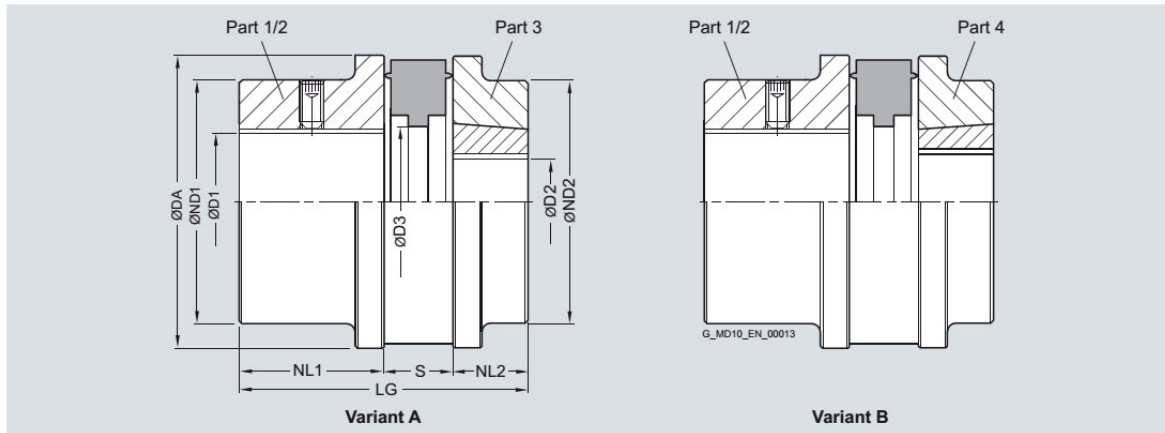

Dimension D3, see type BWN.

Size	Rated torque $T_{KN}$ Nm	Variant	Dimensions in mm										Mass moment of inertia $J$ gm <sup>2</sup>	Product code Order codes for bore diameters and tolerances are specified in catalog section 3	Weight $m$ kg	
			Bore with keyway to DIN 6885-1 max.	Taper clamping bushes Size	Bore with keyway to DIN 6885-1		DA	ND1	ND2	NL1	NL2	S				LG
62	42	A	35	1008	10	25 <sup>1)</sup>	62	58	58	30	23	16	69	0.22	2LC0120-2AE ■■ -0AA0	0.9
		B													2LC0120-2AF ■■ -0AA0	0.9
72	75	A	32	1108	10	28 <sup>1)</sup>	72	54	68	35	23	18	76	0.41	2LC0120-3AE ■■ -0AA0	1.3
		B	42												2LC0120-3AF ■■ -0AA0	1.4
84	130	A	38	1210	11	32	84	64	76	40	26	21	87	0.85	2LC0120-4AE ■■ -0AA0	1.8
		B	48												2LC0120-4AF ■■ -0AA0	1.9
112	360	A	48	1610	14	42 <sup>1)</sup>	112	82	100	60	26	27	113	2.70	2LC0120-6AE ■■ -0AA0	4.1
		B	60												2LC0120-6AF ■■ -0AA0	4.5
142	800	A	60	2012	14	50	142	100	126	75	33	31	139	9.25	2LC0120-8AE ■■ -0AA0	8.0
		B	75												2LC0120-8AF ■■ -0AA0	8.9
182	1750	A	75	2517	16	60	182	126	126	90	45	42	177	27.0	2LC0121-1AE ■■ -0AA0	15.5
		B	90												2LC0121-1AF ■■ -0AA0	16.7
202	2650	A	80	3020	25	75	202	134	168	100	52	48	200	52.5	2LC0121-2AE ■■ -0AA0	20
		B	100												2LC0121-2AF ■■ -0AA0	23
227	3700	A	90	3535	35	90	227	150	180	110	90	54	254	30.0	2LC0121-3AE ■■ -0AA0	35
		B	110												2LC0121-3AF ■■ -0AA0	37.5

ØD1: • Without finished bore – Without order codes for diameter and tolerance

• With finished bore – With order codes for diameter and tolerance (product code without **-Z**)

ØD2: • Without Taper clamping bush – Without order codes for diameter and tolerance

• With Taper clamping bush – With order codes for diameter (product code without **-Z**)

Mass moment of inertia  $J$  in gm<sup>2</sup>, 1 gm<sup>2</sup> = 0.001 kgm<sup>2</sup>, with reference to one coupling half.

Weight and mass moments of inertia apply to maximum bore diameters.

## Ordering example:

BIPEX BNT coupling, size 62, variant B  
Part 1/2: Bore D1 20H7 mm, with keyway to DIN 6885-1 and set screw,  
Part 4: Bore D2 22H7 mm, with keyway to DIN 6885-1 and set screw.

Product code:

**2LC0120-2AF99-0AA0**  
**L0M+M0N**

<sup>1)</sup> Bores, some with shallow keyway, see catalog section 14.

# FLENDER Standard Couplings

## Flexible Couplings – BIPEX Series

### Spare and wear parts

#### Selection and ordering data

##### *BIPEX cam ring*

Size	Product code	Weight kg
43	2LC0120-0WA00-0AA0	0.004
53	2LC0120-1WA00-0AA0	0.005
62	2LC0120-2WA00-0AA0	0.008
72	2LC0120-3WA00-0AA0	0.013
84	2LC0120-4WA00-0AA0	0.021
97	2LC0120-5WA00-0AA0	0.034
112	2LC0120-6WA00-0AA0	0.062
127	2LC0120-7WA00-0AA0	0.082
142	2LC0120-8WA00-0AA0	0.14
162	2LC0121-0WA00-0AA0	0.18
182	2LC0121-1WA00-0AA0	0.3
202	2LC0121-2WA00-0AA0	0.4
227	2LC0121-3WA00-0AA0	0.54

The elastomer cam rings are wear parts. The service life depends on the operating conditions.