



# Demi HBA Filter Housing

- industrial and beverage air / gas

- Flow efficient range of air / gas housings
- Designed to maximise flow and minimise pressure drop
- Designed specifically for the food and beverage industry



## Specification

### Materials of Construction

- Housing: 316L Stainless Steel
- Body Seal: Silicone FDA
- Vent / Drain Seal: PTFE FDA

### Surface Finish

- Internal: Unpolished 1 µm Ra Typical
  - External: Polished 0.8 µm Ra
- All finishes pickled & passivated.*

### Welding

All assembly welds are full penetration.  
All welds are crevice and undercut free.  
*Weld finish & detail drawings available upon request.*

### Certification

Supplied as standard with vessel inspection certificate.

### Material Test Certification

EN10204 3.1 supplied upon request.

### Design Code

Housings designed in accordance with the European Council Pressure Equipment Directive (PED) 97/23/EC and the UK Statutory Pressure Equipment Regulations (PER) 1999 N° 2001.

### Design Basis

ASME VIII Division 1.

Working Condition PED 97/23/EC			Maximum Pressure	
Fluid Group	State	Temperature	01A	01B
Non Dangerous & Dangerous	Gas / Vapour	150 °C (302 °F)	10.00 barg (145.03 psig)	10.00 barg (145.03 psig)
PED Conformity Assessment Category			SEP	SEP
Volume (litres)			0.75	0.50

## Physical Characteristics

Bowl Height	Dimensions (mm)			Typical Weight (Kg)
	'A'	'B'	'C'	
A Size 5" (125 mm)	175	300	130	1.5
B Size 2 1/2" (65 mm)	175	245	70	1.4

Dimensions are based on illustration shown (HBACE01ABB-TS).  
For accurate dimensions, please contact Parker domnick hunter.

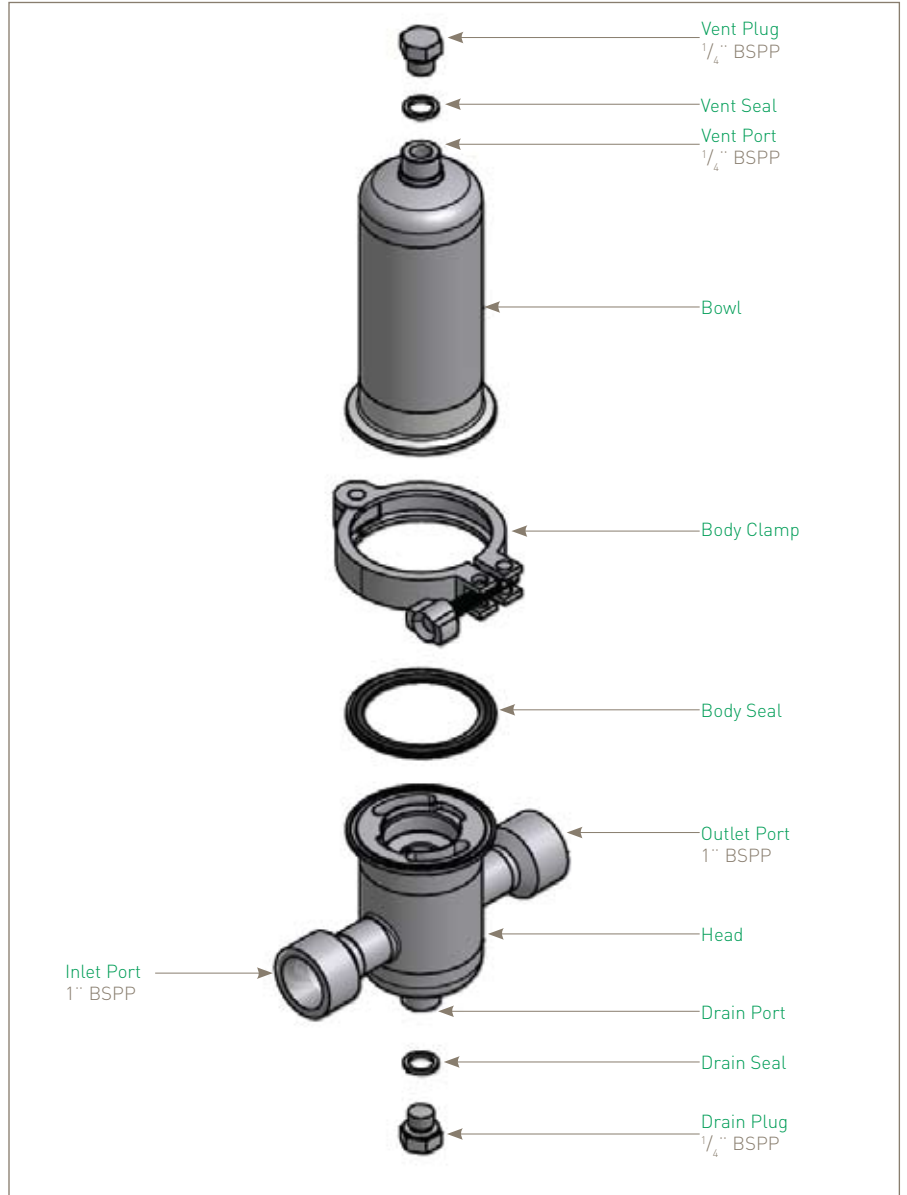
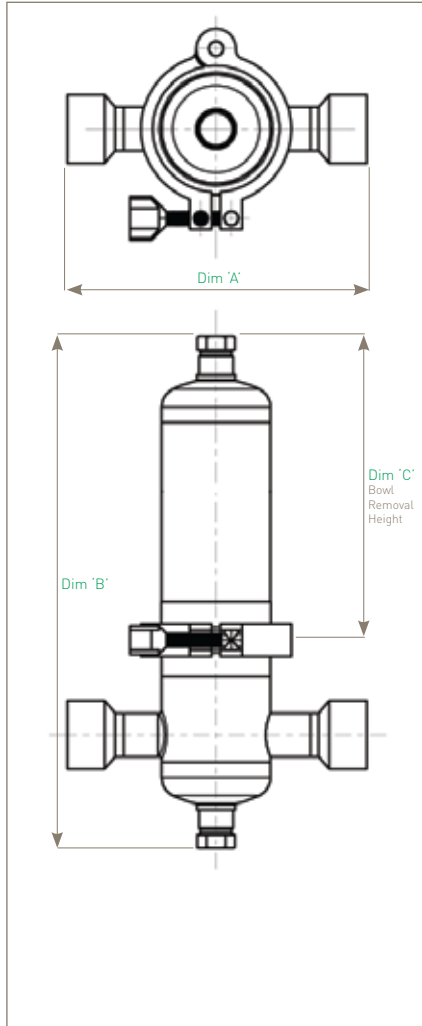

## Ordering Information

<b>HBA</b>	<input type="text"/>	<b>01</b>	<input type="text"/>	<input type="text"/>	<input type="text"/>	<input type="text"/>	<input type="text"/>	<input type="text"/>	<input type="text"/>
Code   Vessel Class	Code   Length (Nominal)	Code   Connection Size	Code   Standard	Code   Cartridge	Code   Seal				
CE Standard	A 5" (125 mm) B 2 1/2" (65 mm)	B 1"	B BSPP N NPT	T 126	S Silicone				

Note: For accessories, i.e. gauges, please contact Parker domnick hunter - Process Division for full availability.

For additional features, Parker domnick hunter offer this housing as part of its Standard PLUS Range.  
Please see HBA® datasheet for more information.

Parker domnick hunter has a continuous policy of product development and although the Company reserves the right to change specifications, it attempts to keep customers informed of any alterations. This publication is for general information only and customers are requested to contact our Process Filtration Sales Department for detailed information and advice on a products suitability for specific applications. All products are sold subject to the company's Standard conditions of sale.